

APPLICATION NOTE

OM5808 demo board negative supply for 2.5 Gb/s TZA3014 / TZA3019 with HBCC package

AN01022

Abstract

This application note describes demo board OM5808. This demo board is designed for customer demonstration of Philips Semiconductors' TZA3014 and TZA3019 ICs with negative supply voltage in HBCC32 package (SOT560AA1). The application note is limited to information not described in the data sheets. Application information includes schematics and layouts.

© Philips Electronics N.V. 2001

All rights are reserved. Reproduction in whole or in part is prohibited without the prior written consent of the copyright owner.

The information presented in this document does not form part of any quotation or contract, is believed to be accurate and reliable and may be changed without notice. No liability will be accepted by the publisher for any consequence of its use. Publication thereof does not convey nor imply any license under patent- or other industrial or intellectual property rights.

APPLICATION NOTE

OM5808 demo board negative supply for 2.5 Gb/s TZA3014/ TZA3019 with HBCC package

AN01022

Author:

Marc van Laer
Philips Semiconductors Systems Laboratory Eindhoven,
The Netherlands

Keywords

Telecom
Optical networks
SDH, SONET
STM16, OC48
CML, PECL
Cross point
Switch
LIM
MUX

Number of pages: 52

Date: 01-05-31

THIS PAGE IS INTENTIONALLY LEFT BLANK

Introduction

This Application note is a short description of the OM5808 demo board. The OM5808 demo board can be used to evaluate the functionality of TZA3014 and TZA3019 at 2.5 Gb/s with negative supply voltage in HBCC32 package (SOT560AA1). demo board OM5809 can be used to evaluate the functionality of TZA3014 and TZA3019 at 2.5 Gb/s with positive supply voltage in HBCC32 package (SOT560AA1). This demo board is described in a separate application note.

Table 1 gives an overview of the possible options for demo board OM5808.

TABLE 1 Options of demo board OM5808

Datarate Gb/s	IC type number	Type	Remark
2.5	TZA3014	Single amplifier	1x LOS output, 1x RSSI output and mute function
2.5	TZA3019A	Dual amplifier	2x RSSI outputs
2.5	TZA3019B	Dual amplifier	1x LOS output and 1x RSSI output
2.5	TZA3019C	Dual amplifier	2x LOS outputs

The application note consists of the following sections:

1. Getting started (Block schematic, test possibilities)
2. General (used acronyms, PCB cross section)
3. Schematics, descriptions
4. Measurements
5. Bill of materials
6. Layout and component placement

THIS PAGE IS INTENTIONALLY LEFT BLANK

TABLE OF CONTENTS

1. Getting started	13
1.1 Block diagram	13
1.2 Overview	14
1.3 OM5808 Demo board	15
1.3.1 What to check?	15
2. General	17
2.1 Acronyms	17
2.2 Cross section of multi layer PCB	18
3. Schematics	19
3.1 TZA3014	20
3.1.1 TZA3014 general	21
3.1.2 Power supply	21
3.1.3 Input & output	21
3.1.4 LOS and RSSI	21
3.1.5 S1 settings	21
3.1.6 S3 settings	21
3.1.7 Mute	21
3.2 Option "A" with TZA3019	22
3.2.1 Option A: General	23
3.2.2 Power supply	23
3.2.3 Inputs & outputs	23
3.2.4 S1 settings	23
3.2.5 RSSI1 and RSSI2	23
3.3 Option "B" with TZA3019	24
3.3.1 Option B: General	25
3.3.2 Description of the application	25
3.3.3 Power supply	25
3.3.4 Inputs & outputs	25
3.3.5 S1 settings	25
3.3.6 LOS1 and RSSI2	25
3.4 Option "C" with TZA3019	26
3.4.1 Option C: General	27
3.4.2 Power supply	27
3.4.3 Inputs & outputs	27
3.4.4 S1 settings	27
3.4.5 LOS1 and LOS2	27
4. Measurements	29
4.1 Measurement of testboard with semirigid connections	30
4.2 Measurement of OM5808 demo board	31
4.3 Crosstalk on demo board OM5808 between Ch1 and Ch2	32
4.4 Output waveforms measured on OM5808 demo board	33
4.5 Waveforms	34
4.5.1 TZA3019, output: 200 mV	34
4.5.2 TZA3019, output: 800 mV	34
4.6 Eye pattern	35

**OM5808 demo board negative supply for 2.5 Gb/s
TZA3014 / TZA3019 with HBCC package**

**Application Note
AN01022**

4.6.1	Input signal	35
4.6.2	Output signal, 800 mV pp	35
5.	Bill of materials	37
5.1	TZA3014	37
5.2	TZA3019 “A” option.	38
5.3	TZA3019 “B” option.	40
5.4	TZA3019 “C” option.	42
5.5	Layout considerations	43
5.6	Thermal considerations.	43
6.	Layout	45
6.1	Silk screen (top)	45
6.2	Top layer component placement	46
6.3	Top layer copper, inverted	47
6.4	First inner layer copper, inverted	48
6.5	Second inner layer copper, inverted	49
6.6	Bottom layer copper, inverted	50
6.7	Bottom component placement (bottom view).	51
6.8	Silk screen (bottom view)	52

LIST OF TABLES

TABLE 1	Options of demo board OM5808	5
TABLE 2	Demo board options for TZA3014 & TZA3019 described in this application note.	14
TABLE 3	Other demo board for TZA3014 & TZA3019	14
TABLE 4	Settings of switch S1	23
TABLE 5	Settings of switch S2 and S3	23
TABLE 6	Settings of switch S1	25
TABLE 7	Settings of switch S1	27
TABLE 8	Settings of switch S2 and S3	27
TABLE 9	Bill of materials TZA3014, sorted by reference.	37
TABLE 10	Bill of materials TZA3019A, sorted by reference.. . . .	38
TABLE 11	Bill of materials TZA3019B, sorted by reference.. . . .	40
TABLE 12	Bill of materials TZA3019C, sorted by reference.. . . .	42

THIS PAGE IS INTENTIONALLY LEFT BLANK

LIST OF FIGURES

Fig.1	OM5808 demo board block diagram	13
Fig.2	OM5808 demo board	15
Fig.3	Cross section of multi layer PCB	18
Fig.4	Schematic of OM5808 demo board with all options, negative supply	19
Fig.5	Schematic of OM5808 demo board with TZA3014	20
Fig.6	Schematic of OM5808 demo board with TZA3019A	22
Fig.7	Schematic of OM5808 demo board with TZA3019B	24
Fig.8	Schematic of OM5808 demo board with TZA3019C	26
Fig.9	Measurement setup of gain transfer characteristic	29
Fig.10	Measurement setup of output waveforms	33

THIS PAGE IS INTENTIONALLY LEFT BLANK

1. Getting started

1.1 Block diagram

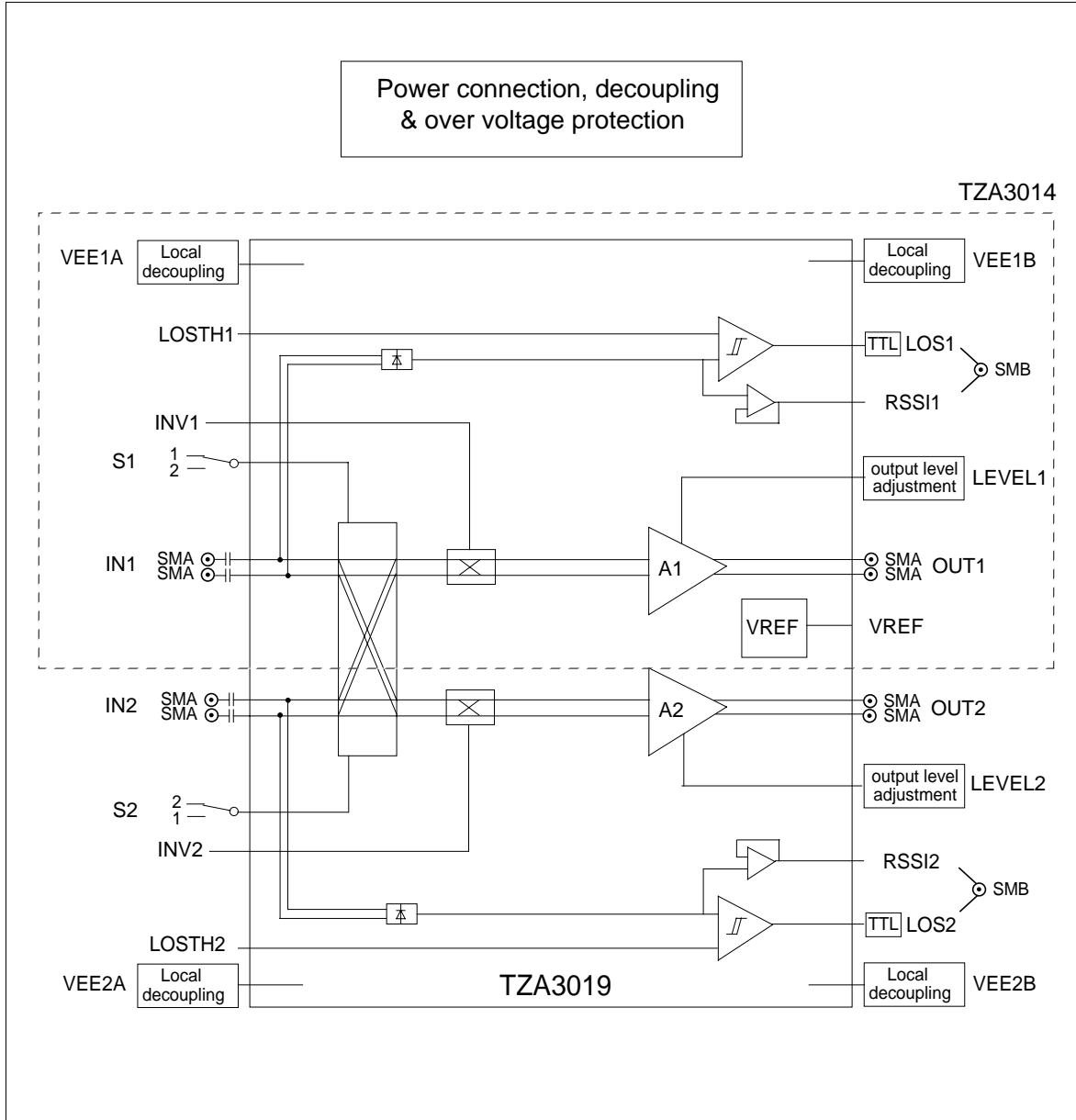

Fig.1 OM5808 demo board block diagram

**OM5808 demo board negative supply for 2.5 Gb/s
TZA3014 / TZA3019 with HBCC package**

**Application Note
AN01022**

1.2 Overview

Table 2 shows the options of demo board OM5808 described in this application note.

TABLE 2 Demo board options for TZA3014 & TZA3019 described in this application note.

Demo board No.	IC type	Package	Supply	Remark	Ap. note Nr.
OM5808	TZA3014	HBCC32	-3.3 Volt	single limiter 1x RSSI & 1x LOS	AN01022
OM5808	TZA3019A	HBCC32	-3.3 Volt	dual limiter 2x RSSI	AN01022
OM5808	TZA3019B	HBCC32	-3.3 Volt	dual limiter 1x RSSI & 1x LOS	AN01022
OM5808	TZA3019C	HBCC32	-3.3 Volt	dual limiter 2 LOS	AN01022

Table 3 shows the options of demo board OM5809. This demo board is described in a separate application note.

TABLE 3 Other demo board for TZA3014 & TZA3019

Demo board No.	IC type	Package	Supply	Remark	Ap. note Nr.
OM5809	TZA3014	HBCC32	+3.3 Volt	single limiter 1x RSSI & 1x LOS	AN01023
OM5809	TZA3019A	HBCC32	+3.3 Volt	dual limiter 2x RSSI	AN01023
OM5809	TZA3019B	HBCC32	+3.3 Volt	dual limiter 1x RSSI & 1x LOS	AN01023
OM5809	TZA3019C	HBCC32	+3.3 Volt	dual limiter 2 LOS	AN01023

1.3 OM5808 Demo board

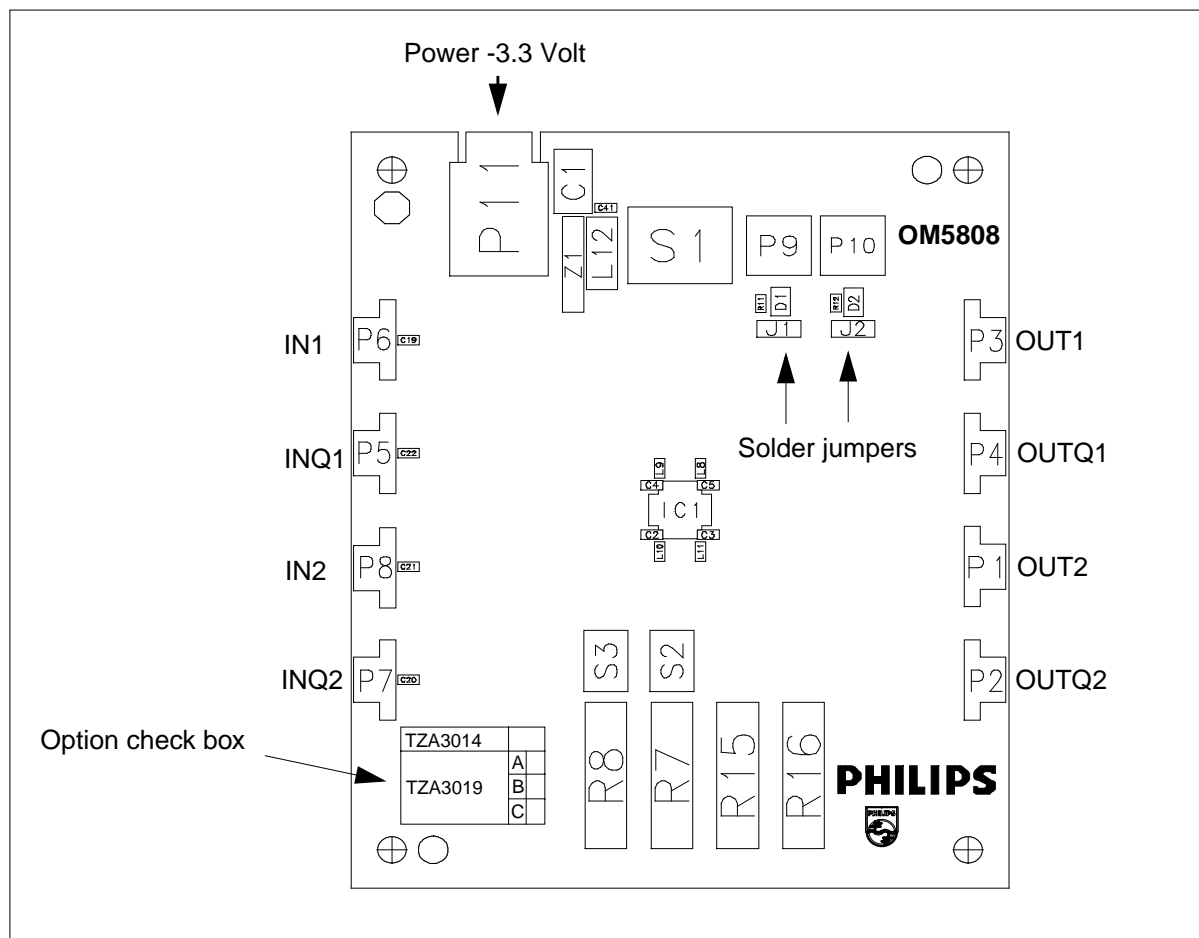

Fig.2 OM5808 demo board

1.3.1 What to check?

- First check the "option check box" on the demo board for the IC type and application.
- Connecting the power: check the polarity of the power supply, adjust current limit to 400mA. Although the demo board is protected against over voltage and wrong polarity, the supply current has to be limited.
- Check if solder jumper J1 & J2 are configured as follows:

TZA3014: default the mute function is used, R11 has to be connected to GND using J1. Solder jumper J2 is left open (S1-1 is switched off and S3 must be switched on).

TZA3019A: both solder jumpers J1 & J2 are left open.

TZA3019B: default the "auto switch" function is used, R11 has to be connected to GND using J1. Solder jumper J2 is left open (S1-1 and S1-2 are switched off).

TZA3019C: Default the LEDs, D1 and D2, are used to observe the LOS outputs. The LEDs have to be connected to GND using J1 and J2.

THIS PAGE IS INTENTIONALLY LEFT BLANK

2. General

2.1 Acronyms

- 2.5 Gbps 2,488,320 kbps
- 2.5 GHz 2,488,320 kHz
- 2G5 2.5 GHz
- Cu Copper
- GND Ground
- HBCC Plastic, exposed diepad Bump Chip Carrier
- HTQFP Plastic, exposed diepad Thin Quad Flat Package
- IC Integrated Circuit
- LOS Loss Of Signal
- LOSTH Loss Of Signal Threshold
- MUX Multiplexer
- PCB Printed Circuit Board
- Pxxx Identification label for pins, buses and connectors
- ..Q indication for inverted signal
- RSSI Receive Signal Strength Indicator
- SDH Synchronous Digital Hierarchy
- SMA RF connector 50 ohm system impedance
- SMB Small outline DC connectors
- SMD Surface Mounted Device
- SONET Synchronous Optical Networks
- STM 16 Synchronous Transport Module no. 16
- TZA Type number indication

2.2 Cross section of multi layer PCB

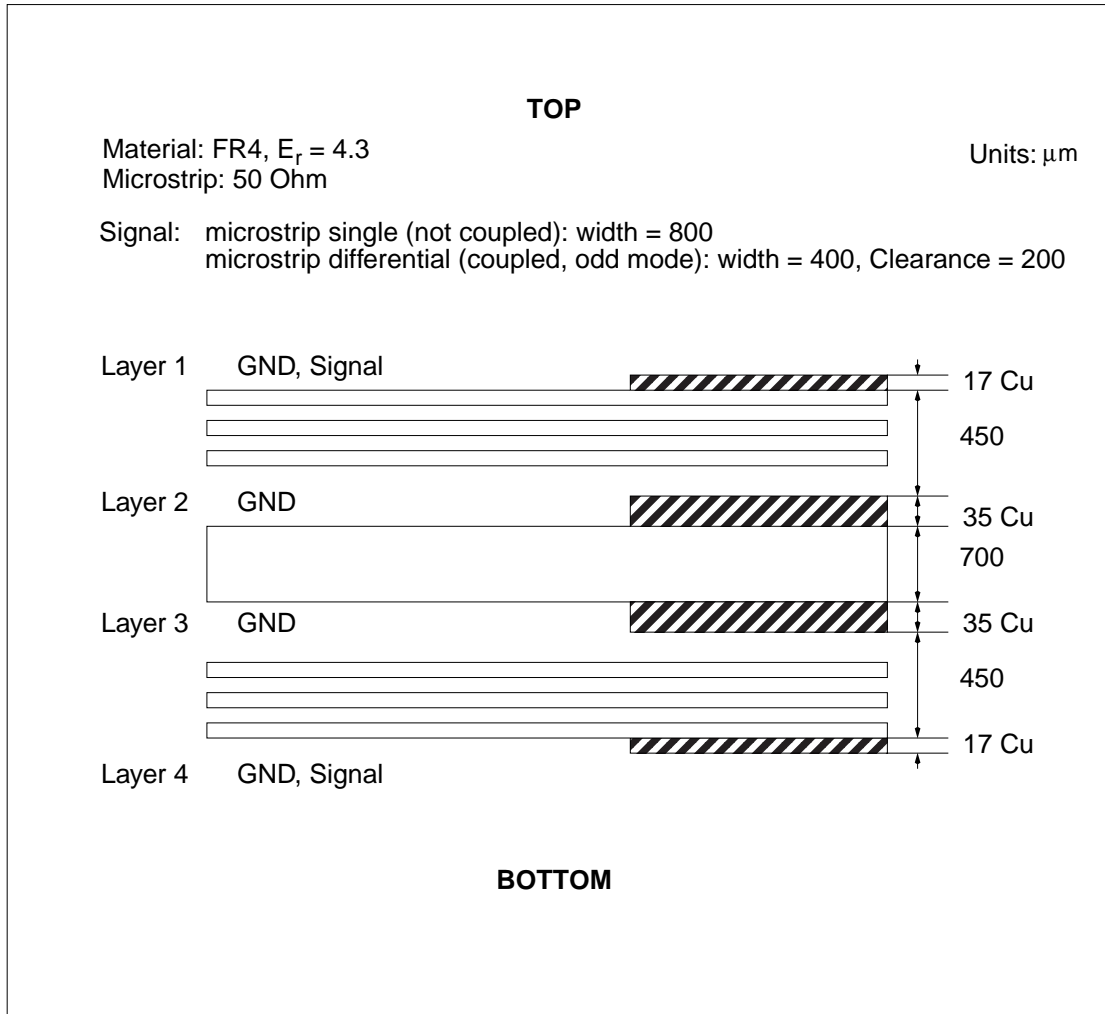

Fig.3 Cross section of multi layer PCB

**OM5808 demo board negative supply for 2.5 Gb/s
TZA3014 / TZA3019 with HBCC package**

**Application Note
AN01022**

3. Schematics

For reading convenience the schematics are printed opposite of the description, therefore some information will be duplicated.

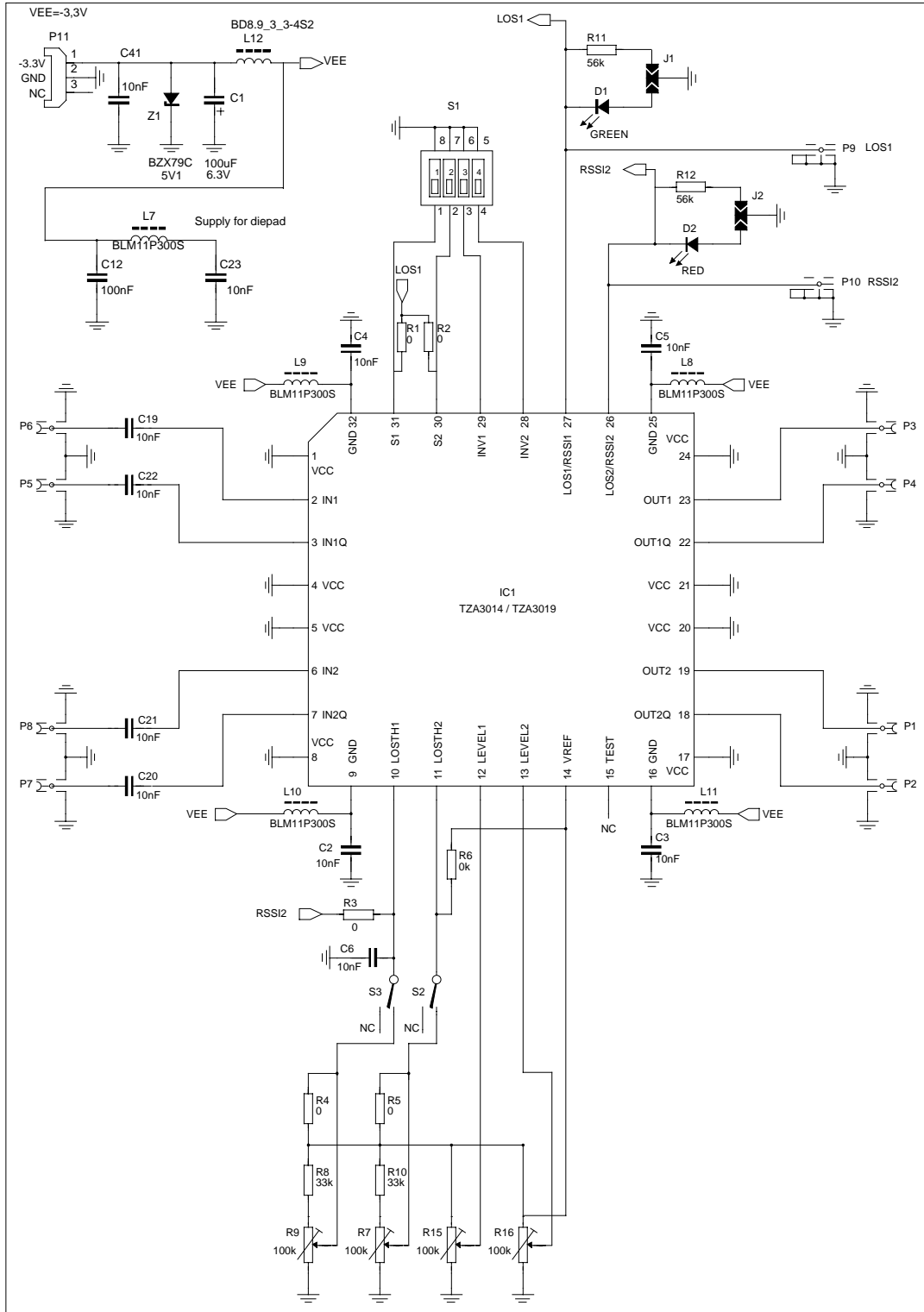

Fig.4 Schematic of OM5808 demo board with all options, negative supply

**OM5808 demo board negative supply for 2.5 Gb/s
TZA3014 / TZA3019 with HBCC package**

**Application Note
AN01022**

3.1 TZA3014

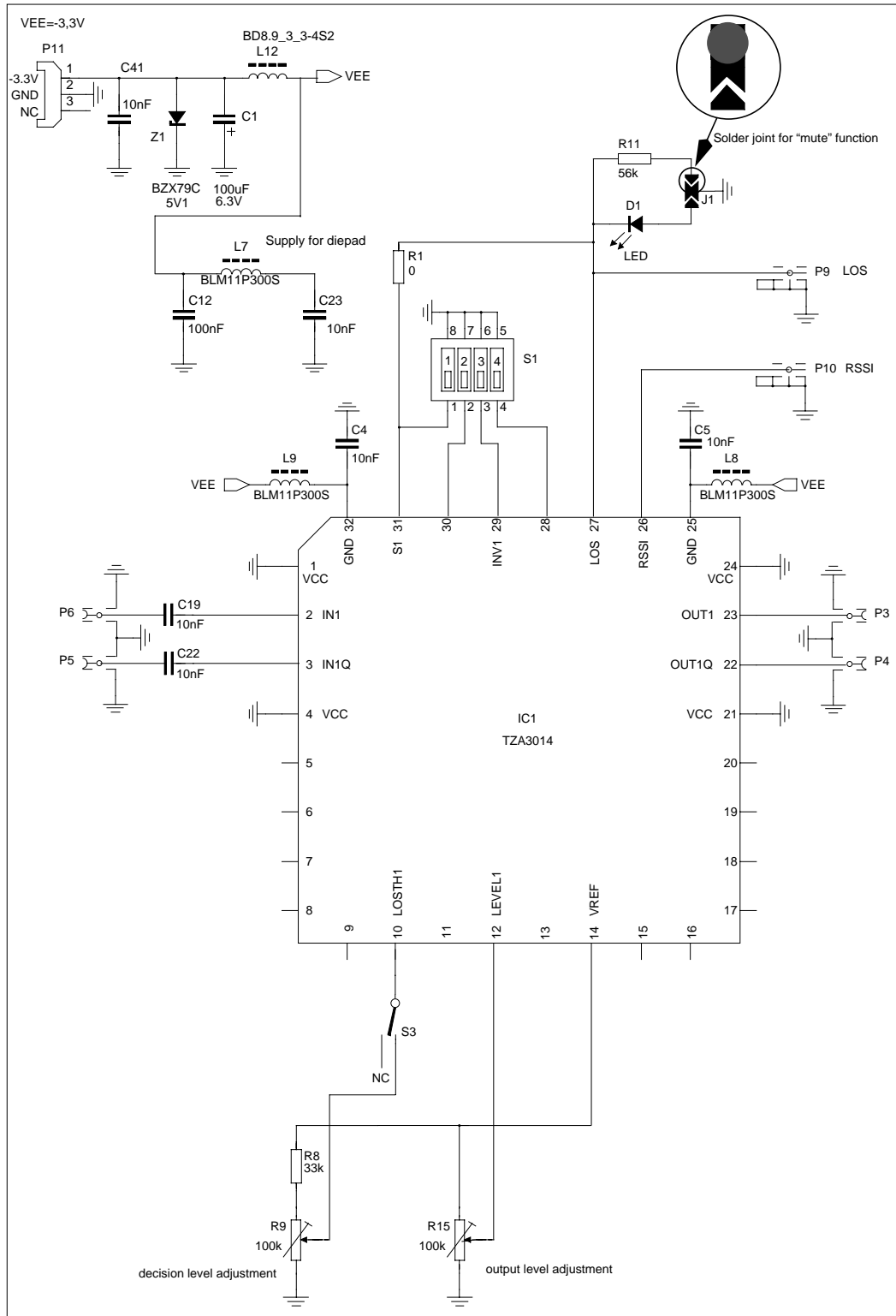

Fig.5 Schematic of OM5808 demo board with TZA3014

3.1.1 TZA3014 general

The TZA3014 is a 2.5 Gb/s postamplifier with a digital Loss Of Signal detector and a Received Signal Strength Indicator.

3.1.2 Power supply

P11-1: -3.3 volt, P11-2: GND, P11-3: not connected.

C1, C41, L12 and C12, C23, L7 are decoupling networks for the power supply.

Z1 is added to protect the circuit against over voltage.

C4 & L9 and C5 & L8 are local decoupling networks.

3.1.3 Input & output

The TZA3014 has a differential input which is AC coupled (C19 and C22). The input signal has to be connected to the SMA connectors P5 & P6. The output of the TZA3014 is differential and is DC coupled, the output has to be connected to SMA connectors P3 and P4. With R15 (LEVEL1) the output level can be adjusted.

3.1.4 LOS and RSSI

On the TZA3014, the digital Loss Of Signal output (LOS) is available on pin 27. The Received Signal Strength Indicator (RSSI) is available on pin 26. These outputs can be observed at SMB connectors P9 (LOS) and P10 (RSSI). LOS: if the input signal level is below the threshold level, LOS1 (pin 27) will be high. When D1 is connected to ground, using solder joint J1, the green LED will extinguish. If the LED is not used, resistor R11 has to be connected to ground (J1) as load for pin 27.

3.1.5 S1 settings

When the mute function is used, switch S1-1 has to be switched off, if S1-1 is switched on the TZA3014 is muted permanently. With switch S1-3 it is possible to invert output1.

3.1.6 S3 settings

With switch S3 the Loss Of Signal detector and the Received Signal Strength Indicator can be switched in active or in power down mode. If S3 is switched to active mode, the decision level of the input level detector can be adjusted by the resistor network R8 + R9.

Note: when the LOS and RSSI outputs are not used (S3 switched off), R1 has to be removed otherwise the TZA3014 is muted permanently.

3.1.7 Mute

The TZA3014 has a mute function. The LOS output (pin 27) has to be connected to S1 (pin 31) via R1. When the input signal is below the LOSTH1, the LOS output (pin 27) will be high. which forces S1 (pin 31) to be high. When S1 (pin 31) is high the TZA3014 is muted.

Note: when the mute function is used, switch S1-1 has to be switched off and the LOS and RSSI (S3) must be in active mode.

**OM5808 demo board negative supply for 2.5 Gb/s
TZA3014 / TZA3019 with HBCC package**

**Application Note
AN01022**

3.2 Option "A" with TZA3019

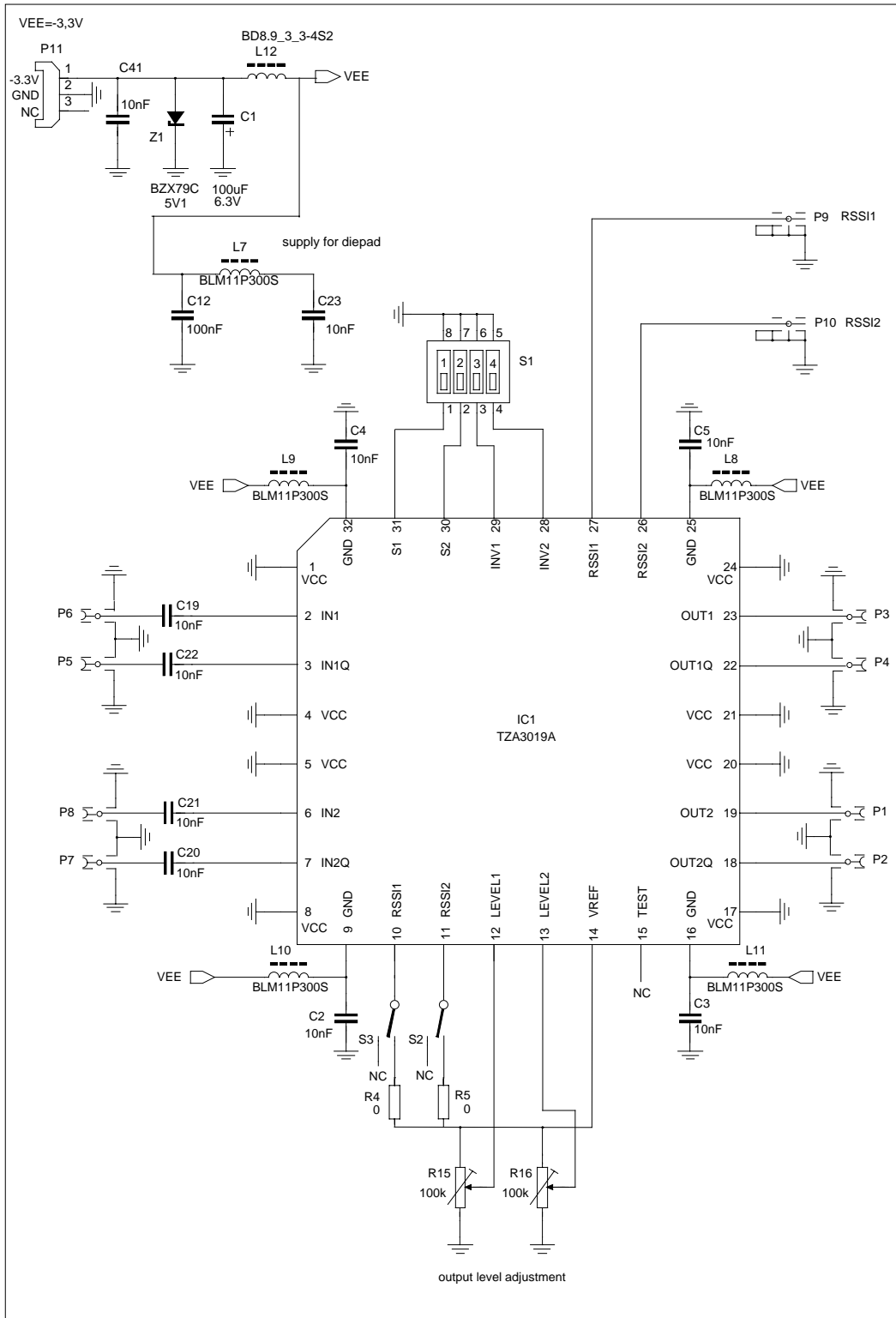

Fig.6 Schematic of OM5808 demo board with TZA3019A

3.2.1 Option A: General

The TZA3019 is a 2.5 Gb/s dual postamplifier. Option “A” has two Received Signal Strength Indicators.

3.2.2 Power supply

P11-1: -3.3 volt, P11-2: GND, P11-3: not connected

C1, C41, L12 and C12, C23, L7 are decoupling networks for the power supply.

Z1 is added to protect the circuit against over voltage.

C4 & L9, C5 & L8, C2 & L10 and C3 & L11 are local decoupling networks.

3.2.3 Inputs & outputs

The TZA3019A has two differential inputs which are AC coupled (C19, C22, C21 and C20). The input signals should be connected to the SMA connectors P5 & P6 and P7 & P8. The two outputs of the TZA3019A are differential and they are DC coupled, the outputs should be connected to SMA connectors P3 & P4 and P1 & P2. With R15 (LEVEL1) and R16 (LEVEL2) the output level of each output can be adjusted.

3.2.4 S1 settings

By setting S1 the output configuration can be chosen. For each output, the input can be selected (S1-1 & S1-2). It is also possible to invert the outputs (S1-3 & S1-4). Table 4 gives an overview of the possible S1 settings.

TABLE 4 Settings of switch S1

S1-1	OUT1	S1-2	OUT2	S1-3	OUT1	S1-4	OUT2
off	input 1	off	input 2	off	OUT1	off	OUT2
on	input 2	on	input 1	on	OUT1Q	on	OUT2Q

3.2.5 RSSI1 and RSSI2

Option “A” has two Received Signal Strength Indicators. RSSI1 at pin 27 and RSSI2 at pin 26. These outputs can be observed at SMB connectors P9 (RSSI1) and P10 (RSSI2). With S2 and S3 it is possible to set the Received Signal Strength Indicators in active or power down mode, this is shown in table 5. If pin 10 & 11 are connected to VEE or left open, RSSI will be in power down mode. If pin 10 & 11 are above VEE, RSSI 1 & 2 are active.

TABLE 5 Settings of switch S2 and S3

S2	LOS2	S3	LOS1
off	power down	off	power down
on	active	on	active

**OM5808 demo board negative supply for 2.5 Gb/s
TZA3014 / TZA3019 with HBCC package**

**Application Note
AN01022**

3.3 Option "B" with TZA3019

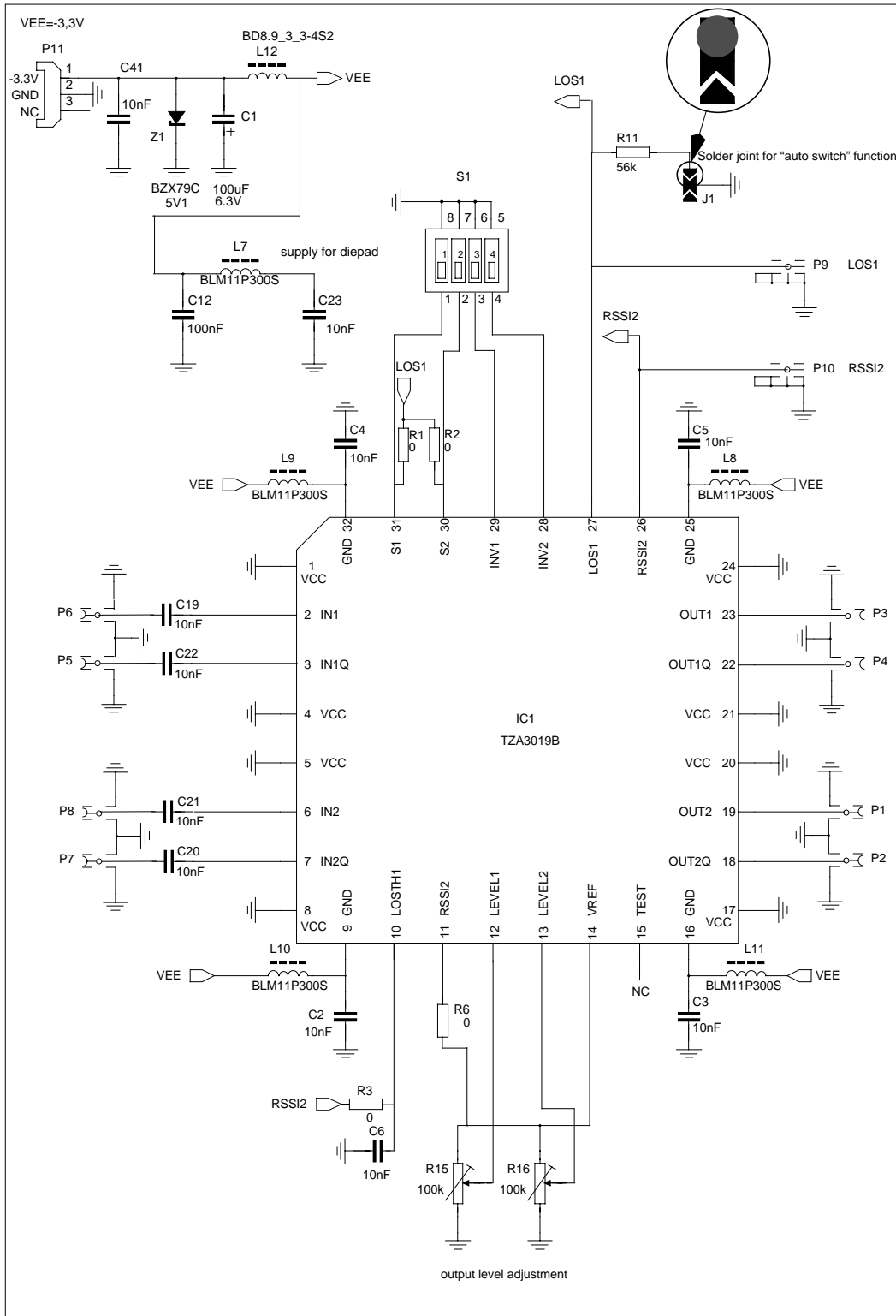

Fig.7 Schematic of OM5808 demo board with TZA3019B

3.3.1 Option B: General

The TZA3019 is a 2.5 Gb/s dual postamplifier. Option “B” has one digital Loss Of Signal detector and one Received Signal Strength Indicator. In this application the strongest input signal will be switched to output1 and the weakest to output2.

3.3.2 Description of the application

If the “auto switch” function is used, the RSSI of input2 must be in active mode and R11 must be connected to ground using solder jumper J1. The signal strength of input2 sets the LOSTH1 of input1. When the input signal of IN1 is above the threshold level, LOS1 (pin 27) will be low. This forces S1 & S2 (pin 31 & 30) to be low. Now OUT1 is connected to IN1 and OUT2 is connected to IN2. If the input signal of IN1 is below the threshold level LOS1 will be high. Now S1 & S2 are also high, OUT1 will be connected to IN2 and OUT2 will be connected to IN1.

3.3.3 Power supply

P11-1: -3.3 volt, P11-2: GND, P11-3: not connected.

C1, C41, L12 and C12, C23, L7 are decoupling networks for the power supply.

Z1 is added to protect the circuit against over voltage.

C4 & L9, C5 & L8, C2 & L10 and C3 & L11 are local decoupling networks.

3.3.4 Inputs & outputs

The TZA3019B has two differential inputs which are AC coupled (C19, C22, C21 and C20). The input signals should be connected to the SMA connectors P5 & P6 and P7 & P8. The two outputs of the TZA3019B are differential and they are DC coupled, the outputs should be connected to SMA connectors P3 & P4 and P1 & P2. With R15 (LEVEL1) and R16 (LEVEL2) the output level of each output can be adjusted.

3.3.5 S1 settings

By setting S1 the output configuration can be chosen. For each output, the input can be selected (S1-1 & S1-2). It is also possible to invert the outputs (S1-3 & S1-4). Table 6 gives an overview of the possible S1 settings.

TABLE 6 Settings of switch S1

S1-1	OUT1	S1-2	OUT2	S1-3	OUT1	S1-4	OUT2
off	input 1	off	input 2	off	OUT1	off	OUT2
on	input 2	on	input 1	on	OUT1Q	on	OUT2Q

Note: when the “auto switch” function is used S1-1 and S1-2 must be switched off.

3.3.6 LOS1 and RSSI2

Option “B” has one digital Loss Of Signal output and one Received Signal Strength Indicator. LOS1 at pin 27 and RSSI2 at pin 26. These outputs can be observed at SMB connectors P9 (LOS1) and P10 (RSSI2). If pin 11 is connected to VEE or left open the Received Signal Strength Indicator will be in power down mode. If pin 11 is above VEE, the RSSI is active. In this application the input (pin11) is biased with R6.

**OM5808 demo board negative supply for 2.5 Gb/s
TZA3014 / TZA3019 with HBCC package**

**Application Note
AN01022**

3.4 Option "C" with TZA3019

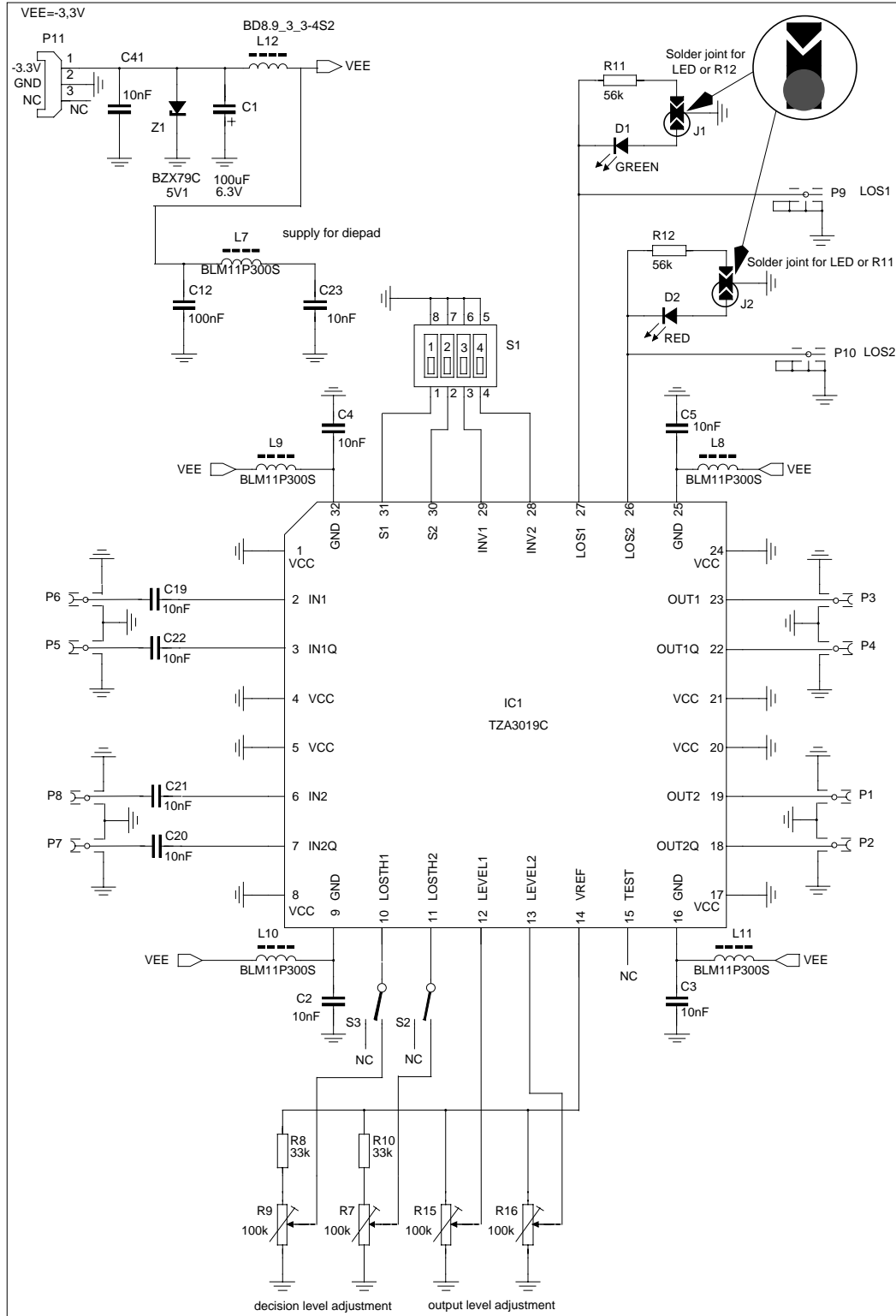

Fig.8 Schematic of OM5808 demo board with TZA3019C

3.4.1 Option C: General

The TZA3019 is a 2.5 Gb/s dual postamplifier. Option “C” has two digital Loss Of Signal detectors.

3.4.2 Power supply

P11-1: -3.3 volt, P11-2: GND, P11-3: not connected.

C1, C41, L12 and C12, C23, L7 are decoupling networks for the power supply.

Z1 is added to protect the circuit against over voltage.

C4 & L9, C5 & L8, C2 & L10 and C3 & L11 are local decoupling networks.

3.4.3 Inputs & outputs

The TZA3019C has two differential inputs which are AC coupled (C19, C22, C21 and C20). The input signals should be connected to the SMA connectors P5 & P6 and P7 & P8. The two outputs of the TZA3019C are differential and they are DC coupled, the outputs should be connected to SMA connectors P3 & P4 and P1 & P2. With R15 (LEVEL1) and R16 (LEVEL2) the output level of each output can be adjusted.

3.4.4 S1 settings

By setting S1 the output configuration can be chosen. For each output, the input can be selected (S1-1 & S1-2). It is also possible to invert the outputs (S1-3 & S1-4). Table 7 gives an overview of the possible S1 settings.

TABLE 7 Settings of switch S1

S1-1	OUT1	S1-2	OUT2	S1-3	OUT1	S1-4	OUT2
off	input1	off	input2	off	OUT1	off	OUT2
on	input2	on	input1	on	OUT1Q	on	OUT2Q

3.4.5 LOS1 and LOS2

Option “C” has two digital Loss Of Signal outputs. LOS1 at pin 27 and LOS2 at pin 26. These outputs can be observed at SMB connectors P9 (LOS1) and P10 (LOS2). When the input signal level of IN1 is below the threshold level (LOSTH1), the LOS1 output will be high (pin 27) and D1 will extinguish. When the input signal level of IN2 is below the threshold level (LOSTH2), the LOS2 output will be high (pin 26) and D2 will extinguish. D1 and D2, have to be connected to ground using solder jumpers J1 & J2. If the LEDs are not used, the resistors R11 & R12 have to be connected to ground (J1 & J2). With S2 and S3 it is possible to set the Loss Of Signal detectors in active or in power down mode, this is shown in table 8. The decision level of the input level detectors can be adjusted by resistor networks R8 + R9 (LOSTH1) and R10 + R7 (LOSTH2).

TABLE 8 Settings of switch S2 and S3

S2	LOS2	S3	LOS1
off	power down	off	power down
on	active	on	active

THIS PAGE IS INTENTIONALLY LEFT BLANK

4. Measurements

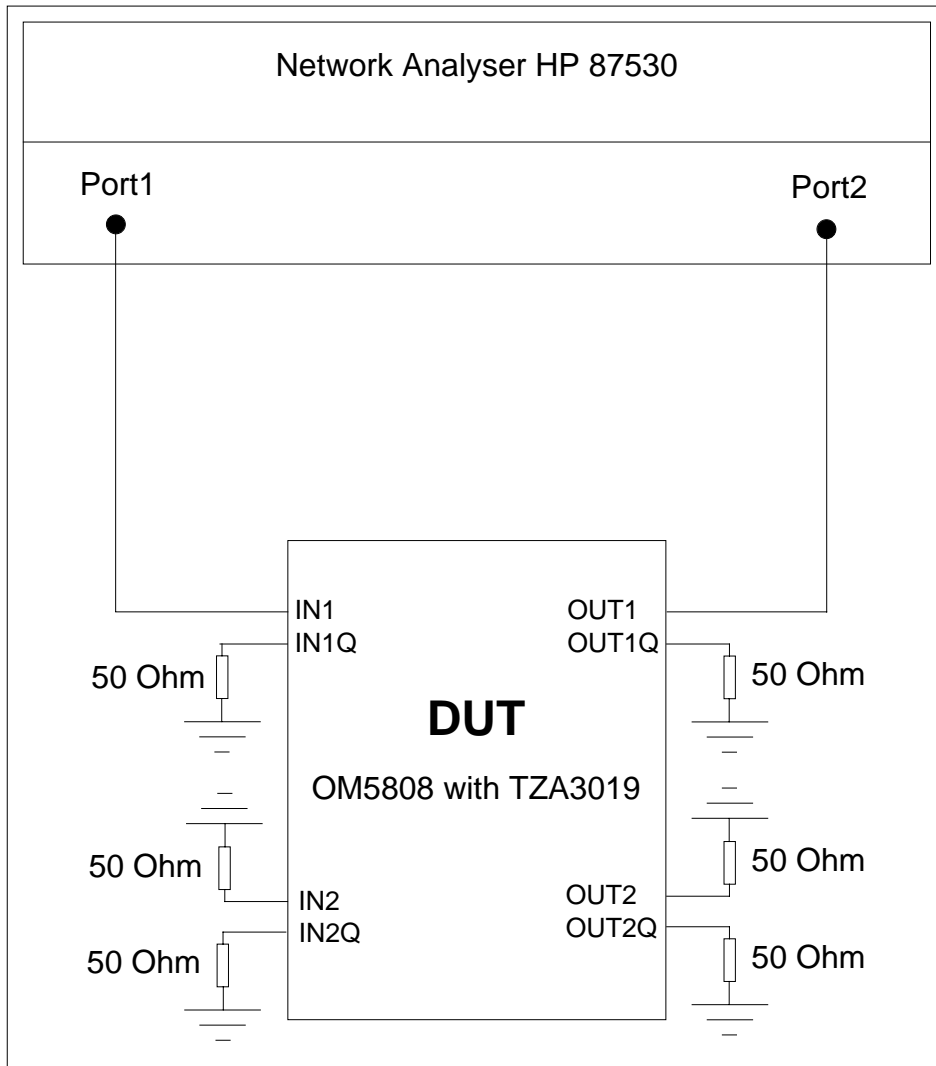
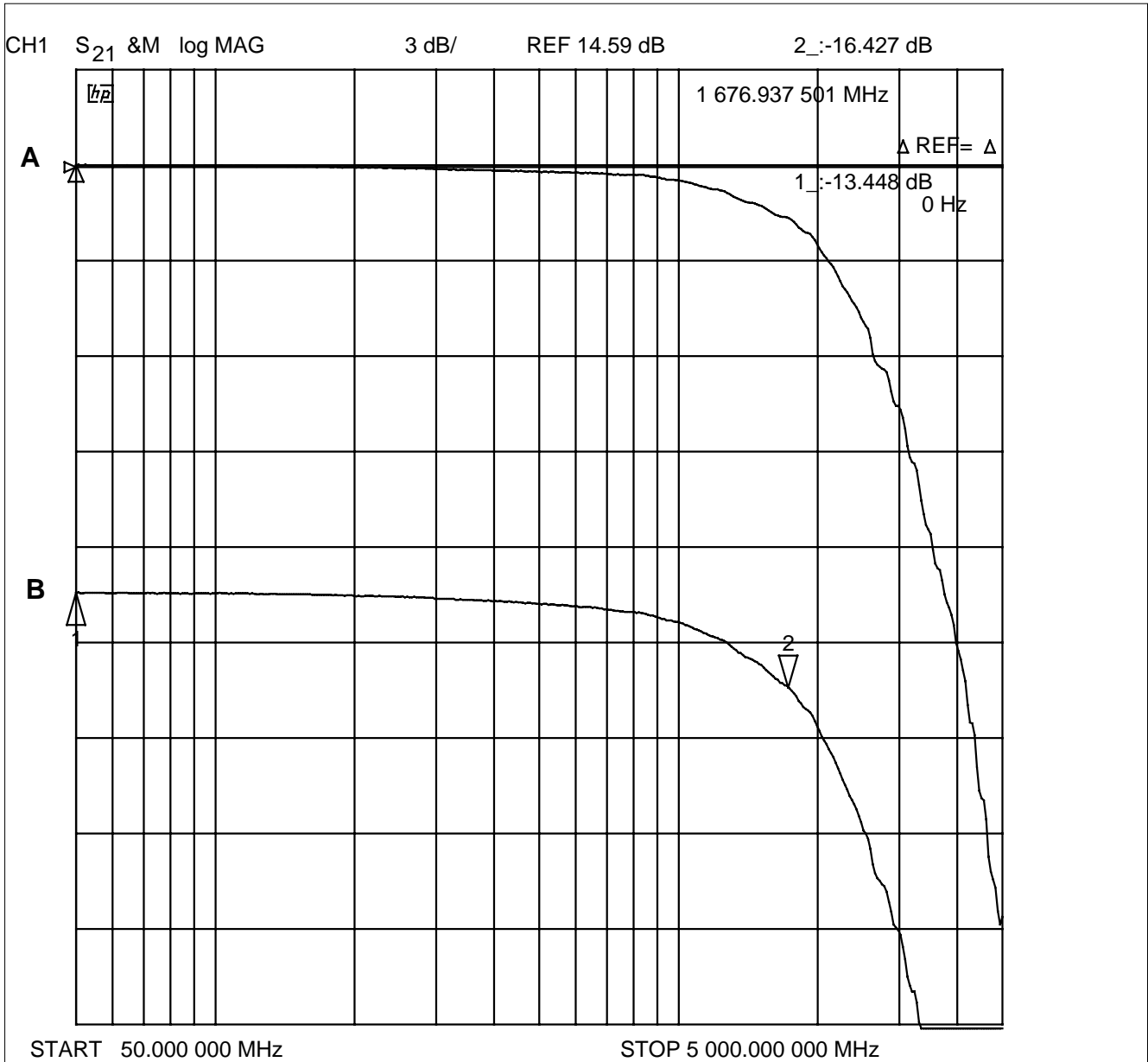

Fig.9 Measurement setup of gain transfer characteristic

4.1 Measurement of testboard with semirigid connections



Input: 50 mV

A: output 800 mV

B: output 200 mV

4.2 Measurement of OM5808 demo board

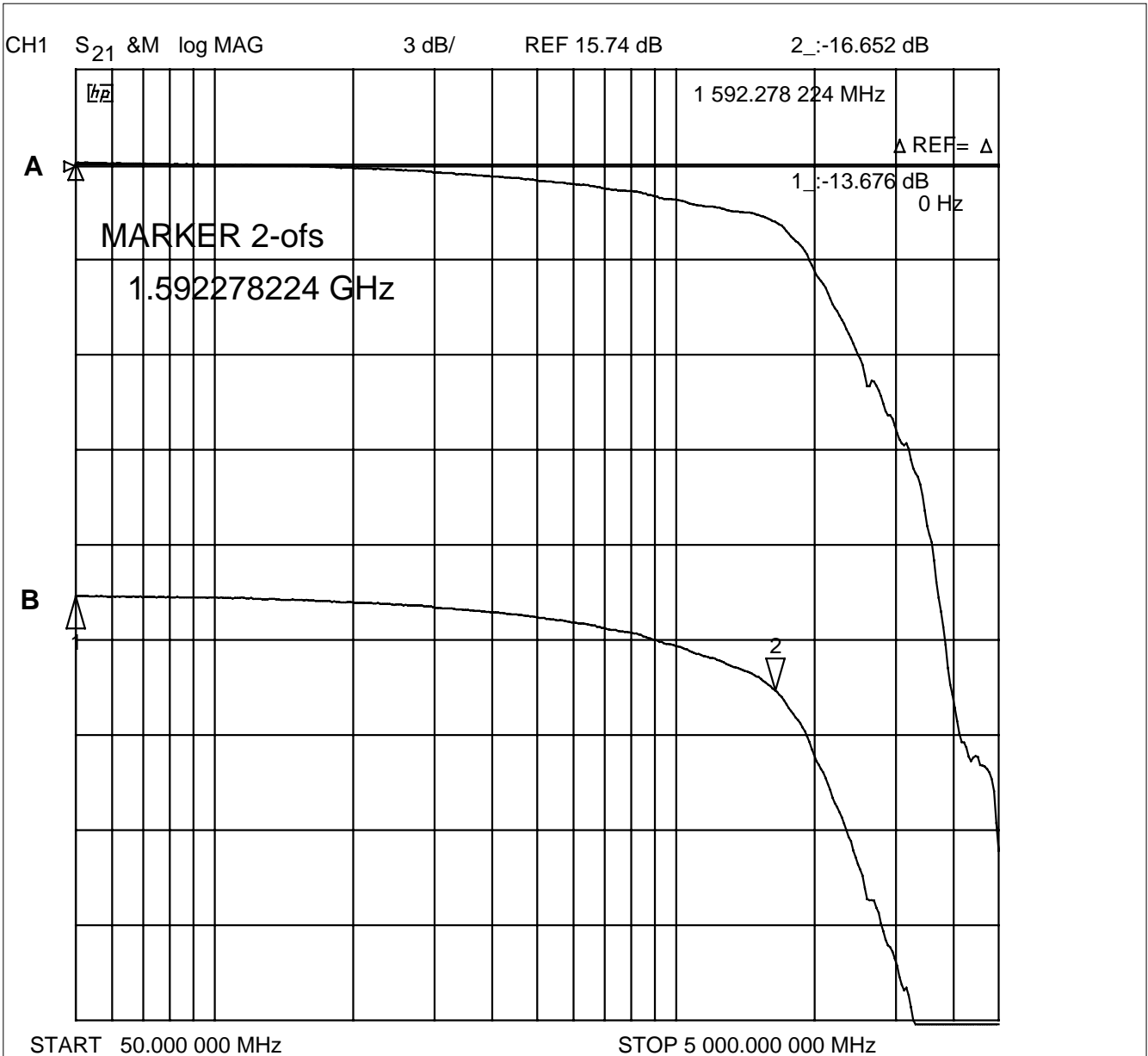

Input: 50 mV

A: output 800 mV

B: output 200 mV

4.3 Crosstalk on demo board OM5808 between Ch1 and Ch2

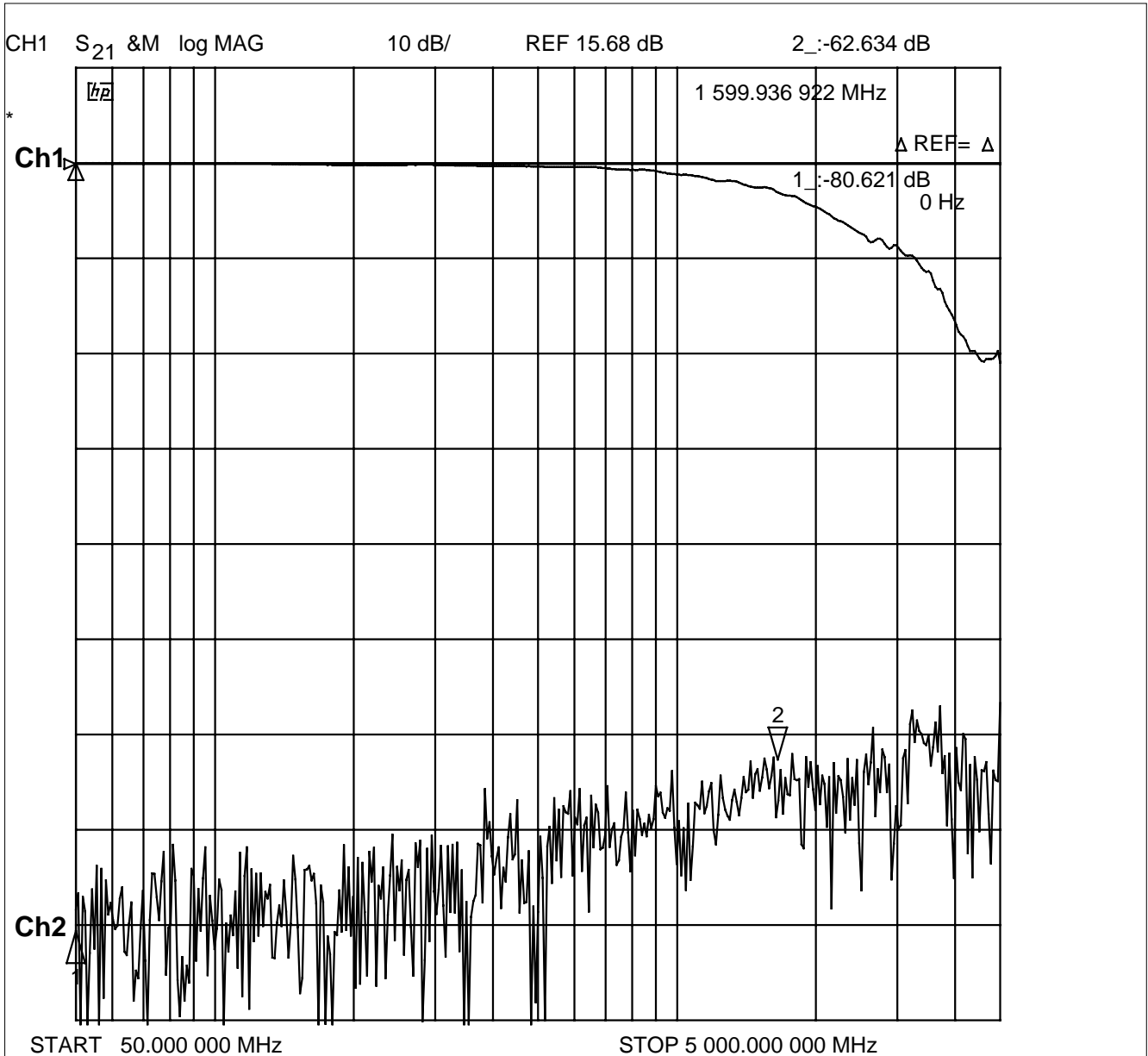

- The same setup as shown in figure 9, was used to measure the crosstalk on the demo board between channel1 and channel2.
- S1-1 was set in “on” position to measure the output of channel2.

4.4 Output waveforms measured on OM5808 demo board

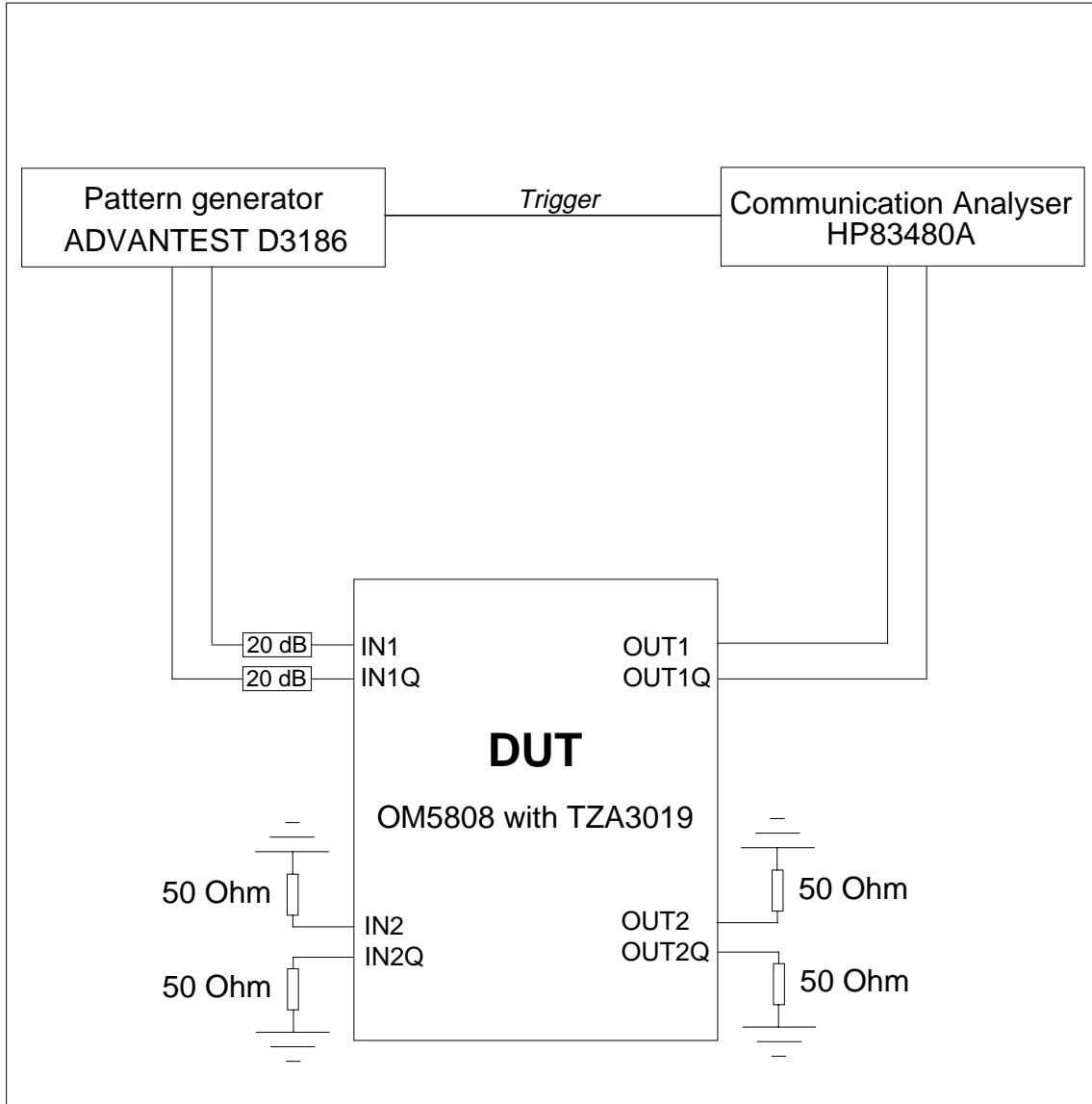
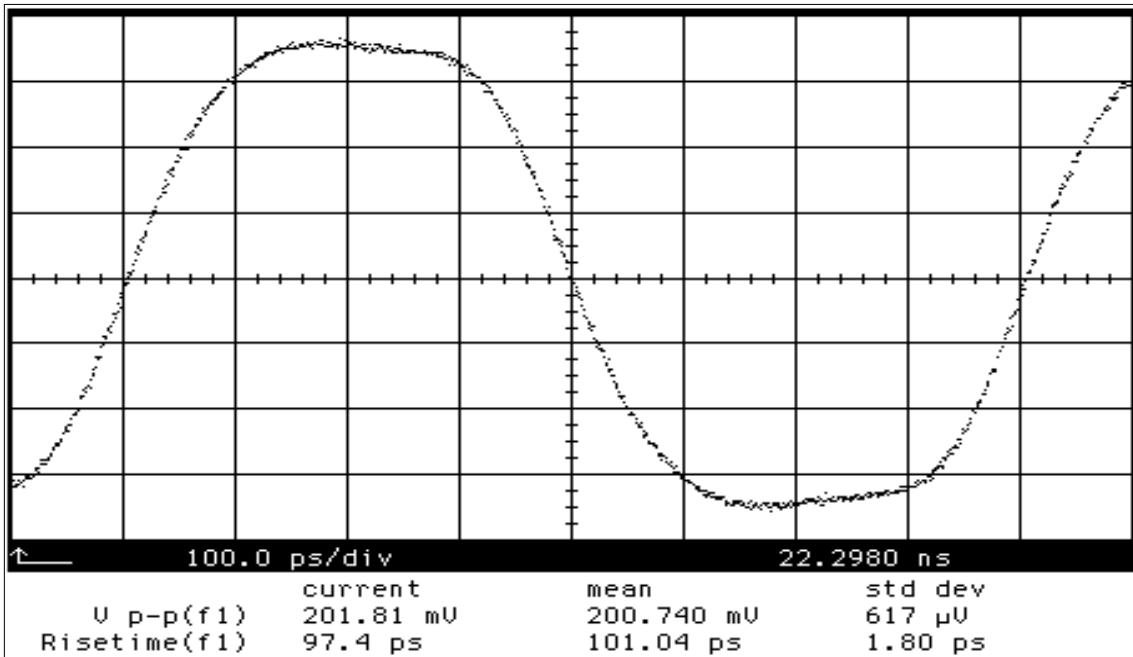

Fig.10 Measurement setup of output waveforms

4.5 Waveforms

4.5.1 TZA3019, output: 200 mV



4.5.2 TZA3019, output: 800 mV

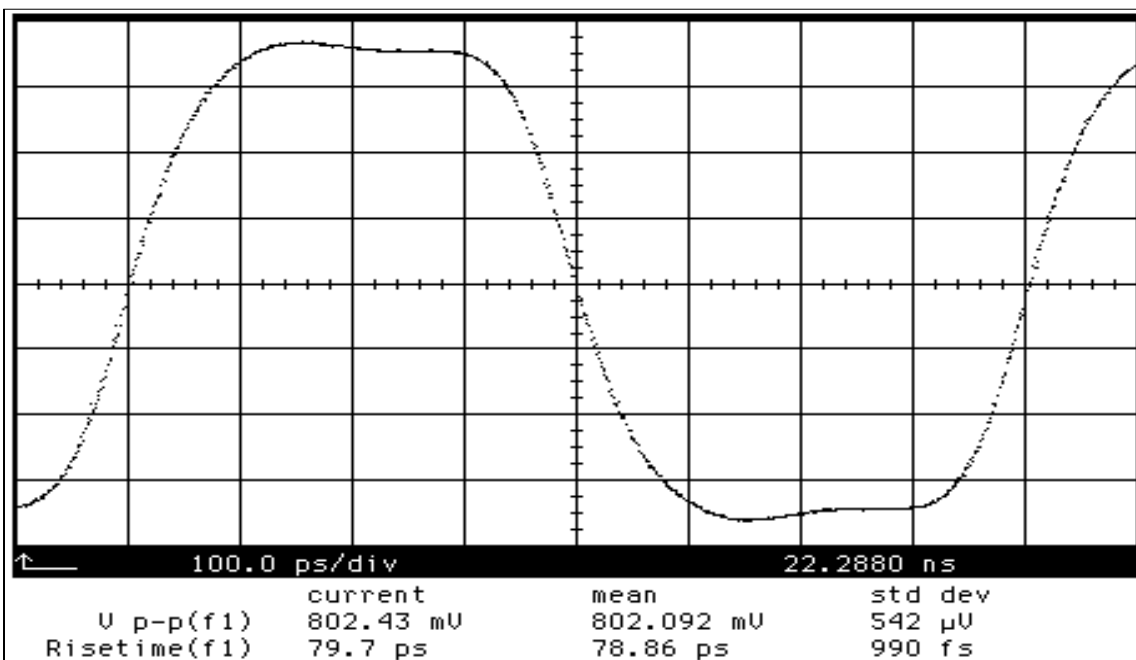

Note: HP70841B pattern generator was used for these measurements.

4.6 Eye pattern

4.6.1 Input signal

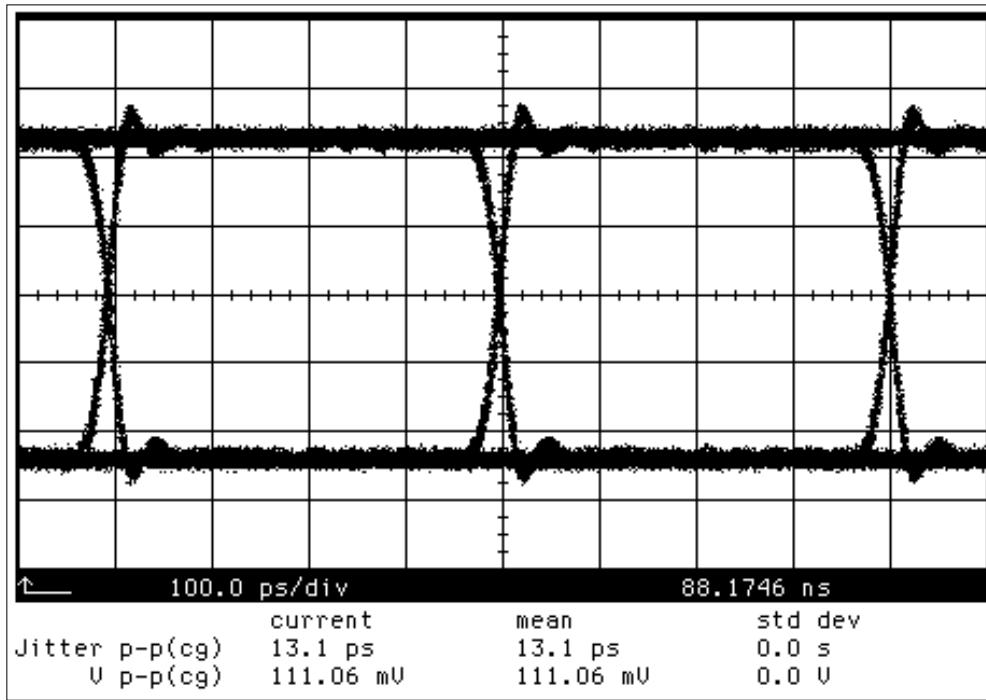

4.6.2 Output signal, 800 mV pp

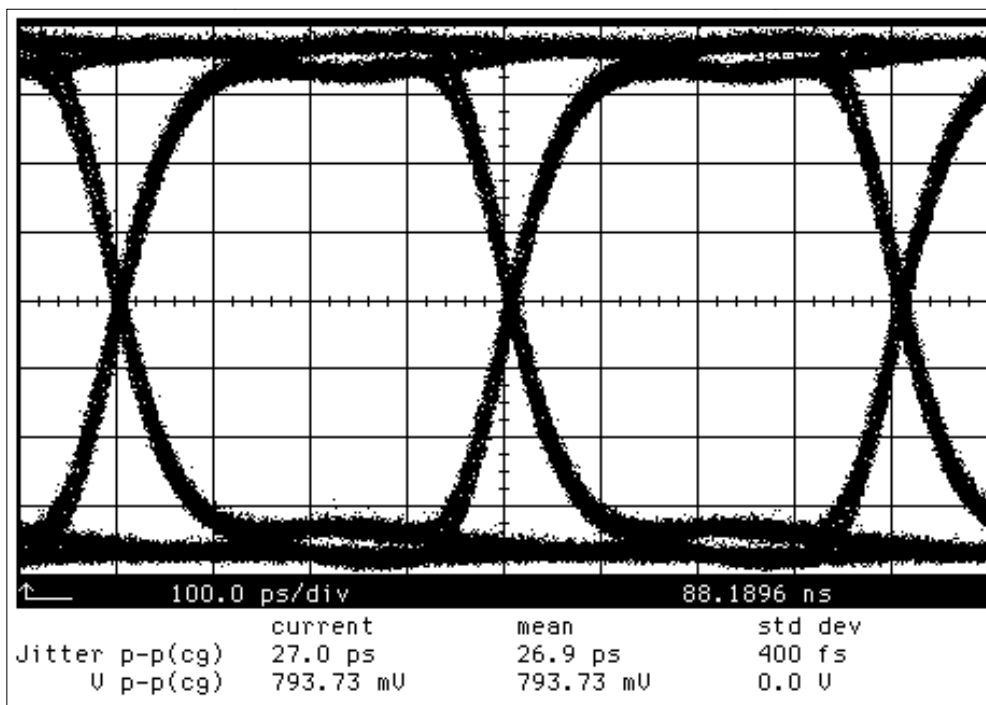

THIS PAGE IS INTENTIONALLY LEFT BLANK

**OM5808 demo board negative supply for 2.5 Gb/s
TZA3014 / TZA3019 with HBCC package**
**Application Note
AN01022**
5. Bill of materials
5.1 TZA3014
TABLE 9 Bill of materials TZA3014, sorted by reference.

REF	Part number	Comp	Series	Vendor	Tolerance	Rating	Geom
C1	B45196H1107M9	100u	B45196	SIEMENS	20%	6.3V	B45_d
C4	2222-916-16736	10n	X7R	PHILIPS	20%	25V	C0603
C5	2222-916-16736	10n	X7R	PHILIPS	20%	25V	C0603
C12	2222-786-16749	100n	X7R	PHILIPS	20%	16V	C0603
C19	2222-916-16736	10n	X7R	PHILIPS	20%	25V	C0603
C22	2222-916-16736	10n	X7R	PHILIPS	20%	25V	C0603
C23	2222-916-16736	10n	X7R	PHILIPS	20%	25V	C0603
C41	2222-916-16736	10n	X7R	PHILIPS	20%	25V	C0603
D1	HLMP6400-011	GREEN	Diffused_Lens	FARNELL			SMDLED
IC1	PN-TZA3014	TZA3014	IC_Universal	PHILIPS			SOT560AA1
L7	BLM11P300S	BLM11P300S	CBD	muRata			BLM11
L8	BLM11P300S	BLM11P300S	CBD	muRata			BLM11
L9	BLM11P300S	BLM11P300S	CBD	muRata			BLM11
L12	4330-030-36301	BD8.933-4S2	CBD	PHILIPS			CBD8.9
P3	142-0701-851	SMA_sqr	COAX	EF.Johnson			SMA_sqr
P4	142-0701-851	SMA_sqr	COAX	EF.Johnson			SMA_sqr
P5	142-0701-851	SMA_sqr	COAX	EF.Johnson			SMA_sqr
P6	142-0701-851	SMA_sqr	COAX	EF.Johnson			SMA_sqr
P9	R114426	SMB_str	COAX	RADIALL			SMB_str
P10	R114426	SMB_str	COAX	RADIALL			SMB_str
P11	3833-1-0-303	MKS3830_3p	MKS3830	STOCKO			3830_3p
R1	2322-702-96001	0	RC21	PHILIPS			R0603
R8	2322-702-60333	33k	RC21	PHILIPS	5%	0.063W	R0603
R9	3006P-7-104BRN	100k	3006P	BOURNS	10%	0.75W	BO3006P
R11	2322-702-60563	56k	RC21	PHILIPS	5%	0.063W	R0603
R15	3006P-7-104BRN	100k	3006P	BOURNS	10%	0.75W	BO3006P
S1	2422-120-00551	DIP-SW_4	print_switch	HONYWELL			SWITCH_4
S3	09-03-201-02	SPDT	print_switch	SPOERLE			Low profile
Z1	9331-177-20153	BZX79C	BZX79C	PHILIPS		5V1	SOD27
	8222-411-48321	PR48321		PS-SLE			BOARD

**OM5808 demo board negative supply for 2.5 Gb/s
TZA3014 / TZA3019 with HBCC package**
**Application Note
AN01022**
5.2 TZA3019 “A” option
TABLE 10 Bill of materials TZA3019A, sorted by reference.

REF	Part number	Comp	Series	Vendor	Tolerance	Rating	Geom
C1	B45196H1107M9	100u	B45196	SIEMENS	20%	6.3V	B45_d
C2	2222-916-16736	10n	X7R	PHILIPS	20%	25V	C0603
C3	2222-916-16736	10n	X7R	PHILIPS	20%	25V	C0603
C4	2222-916-16736	10n	X7R	PHILIPS	20%	25V	C0603
C5	2222-916-16736	10n	X7R	PHILIPS	20%	25V	C0603
C12	2222-786-16749	100n	X7R	PHILIPS	20%	16V	C0603
C19	2222-916-16736	10n	X7R	PHILIPS	20%	25V	C0603
C20	2222-916-16736	10n	X7R	PHILIPS	20%	25V	C0603
C21	2222-916-16736	10n	X7R	PHILIPS	20%	25V	C0603
C22	2222-916-16736	10n	X7R	PHILIPS	20%	25V	C0603
C23	2222-916-16736	10n	X7R	PHILIPS	20%	25V	C0603
C41	2222-916-16736	10n	X7R	PHILIPS	20%	25V	C0603
IC1	PN-TZA3019A	TZA3019A	IC_Universal	PHILIPS			SOT560AA1
L7	BLM11P300S	BLM11P300S	CBD	muRata			BLM11
L8	BLM11P300S	BLM11P300S	CBD	muRata			BLM11
L9	BLM11P300S	BLM11P300S	CBD	muRata			BLM11
L10	BLM11P300S	BLM11P300S	CBD	muRata			BLM11
L11	BLM11P300S	BLM11P300S	CBD	muRata			BLM11
L12	4330-030-36301	BD8.933-4S2	CBD	PHILIPS			CBD8.9
P1	142-0701-851	SMA_sqr	COAX	EF.Johnson			SMA_sqr
P2	142-0701-851	SMA_sqr	COAX	EF.Johnson			SMA_sqr
P3	142-0701-851	SMA_sqr	COAX	EF.Johnson			SMA_sqr
P4	142-0701-851	SMA_sqr	COAX	EF.Johnson			SMA_sqr
P5	142-0701-851	SMA_sqr	COAX	EF.Johnson			SMA_sqr
P6	142-0701-851	SMA_sqr	COAX	EF.Johnson			SMA_sqr
P7	142-0701-851	SMA_sqr	COAX	EF.Johnson			SMA_sqr
P8	142-0701-851	SMA_sqr	COAX	EF.Johnson			SMA_sqr
P9	R114426	SMB_str	COAX	RADIALL			SMB_str
P10	R114426	SMB_str	COAX	RADIALL			SMB_str
P11	3833-1-0-303	MKS3830_3p	MKS3830	STOCKO			3830_3p
R4	2322-702-96001	0	RC21	PHILIPS			R0603
R5	2322-702-96001	0	RC21	PHILIPS			R0603
R15	3006P-7-104BRN	100k	3006P	BOURNS	10%	0.75W	BO3006P
R16	3006P-7-104BRN	100k	3006P	BOURNS	10%	0.75W	BO3006P
S1	2422-120-00551	DIP-SW_4	print_switch	HONYWELL			SWITCH_4
S2	09-03201-02	SPDT	print_switch	SPOERLE			Low profile
S3	09-03201-02	SPDT	print_switch	SPOERLE			Low profile

**OM5808 demo board negative supply for 2.5 Gb/s
TZA3014 / TZA3019 with HBCC package**

**Application Note
AN01022**

TABLE 10 Bill of materials TZA3019A, sorted by reference.

REF	Part number	Comp	Series	Vendor	Tolerance	Rating	Geom
Z1	9331-177-20153	BZX79C	BZX79C	PHILIPS		5V1	SOD27
	8222-411-48321	PR48321		PS-SLE			BOARD

**OM5808 demo board negative supply for 2.5 Gb/s
TZA3014 / TZA3019 with HBCC package**
**Application Note
AN01022**
5.3 TZA3019 “B” option
TABLE 11 Bill of materials TZA3019B, sorted by reference.

REF	Part number	Comp	Series	Vendor	Tolerance	Rating	Geom
C1	B45196H1107M9	100u	B45196	SIEMENS	20%	6.3V	B45_d
C2	2222-916-16736	10n	X7R	PHILIPS	20%	25V	C0603
C3	2222-916-16736	10n	X7R	PHILIPS	20%	25V	C0603
C4	2222-916-16736	10n	X7R	PHILIPS	20%	25V	C0603
C5	2222-916-16736	10n	X7R	PHILIPS	20%	25V	C0603
C6	2222-596-16627	10n	X7R	PHILIPS	10%	50V	C0603
C12	2222-786-16749	100n	X7R	PHILIPS	20%	16V	C0603
C19	2222-916-16736	10n	X7R	PHILIPS	20%	25V	C0603
C20	2222-916-16736	10n	X7R	PHILIPS	20%	25V	C0603
C21	2222-916-16736	10n	X7R	PHILIPS	20%	25V	C0603
C22	2222-916-16736	10n	X7R	PHILIPS	20%	25V	C0603
C23	2222-916-16736	10n	X7R	PHILIPS	20%	25V	C0603
C41	2222-916-16736	10n	X7R	PHILIPS	20%	25V	C0603
IC1	PN-TZA3019B	TZA3019B	IC_Universal	PHILIPS			SOT560AA1
L7	BLM11P300S	BLM11P300S	CBD	muRata			BLM11
L8	BLM11P300S	BLM11P300S	CBD	muRata			BLM11
L9	BLM11P300S	BLM11P300S	CBD	muRata			BLM11
L10	BLM11P300S	BLM11P300S	CBD	muRata			BLM11
L11	BLM11P300S	BLM11P300S	CBD	muRata			BLM11
L12	4330-030-36301	BD8.933-4S2	CBD	PHILIPS			CBD8.9
P1	142-0701-851	SMA_sqr	COAX	EF.Johnson			SMA_sqr
P2	142-0701-851	SMA_sqr	COAX	EF.Johnson			SMA_sqr
P3	142-0701-851	SMA_sqr	COAX	EF.Johnson			SMA_sqr
P4	142-0701-851	SMA_sqr	COAX	EF.Johnson			SMA_sqr
P5	142-0701-851	SMA_sqr	COAX	EF.Johnson			SMA_sqr
P6	142-0701-851	SMA_sqr	COAX	EF.Johnson			SMA_sqr
P7	142-0701-851	SMA_sqr	COAX	EF.Johnson			SMA_sqr
P8	142-0701-851	SMA_sqr	COAX	EF.Johnson			SMA_sqr
P9	R114426	SMB_str	COAX	RADIALL			SMB_str
P10	R114426	SMB_str	COAX	RADIALL			SMB_str
P11	3833-1-0-303	MKS3830_3p	MKS3830	STOCKO			3830_3p
R1	2322-702-96001	0	RC21	PHILIPS			R0603
R2	2322-702-96001	0	RC21	PHILIPS			R0603
R3	2322-702-96001	0	RC21	PHILIPS			R0603
R6	2322-702-96001	0	RC21	PHILIPS			R0603
R12	2322-702-60563	56k	RC21	PHILIPS	5%	0.063W	R0603
R15	3006P-7-104BRN	100k	3006P	BOURNS	10%	0.75W	BO3006P

**OM5808 demo board negative supply for 2.5 Gb/s
TZA3014 / TZA3019 with HBCC package****Application Note
AN01022**

TABLE 11 Bill of materials TZA3019B, sorted by reference.

REF	Part number	Comp	Series	Vendor	Tolerance	Rating	Geom
R16	3006P-7-104BRN	100k	3006P	BOURNS	10%	0.75W	BO3006P
S1	2422-120-00551	DIP-SW_4	print_switch	HONYWELL			SWITCH_4
Z1	9331-177-20153	BZX79C	BZX79C	PHILIPS		5V1	SOD27
	8222-411-48321	PR48321		PS-SLE			BOARD

**OM5808 demo board negative supply for 2.5 Gb/s
TZA3014 / TZA3019 with HBCC package**
**Application Note
AN01022**
5.4 TZA3019 “C” option
TABLE 12 Bill of materials TZA3019C, sorted by reference.

REF	Part number	Comp	Series	Vendor	Tolerance	Rating	Geom
C1	B45196H1107M9	100u	B45196	SIEMENS	20%	6.3V	B45_d
C2	2222-916-16736	10n	X7R	PHILIPS	20%	25V	C0603
C3	2222-916-16736	10n	X7R	PHILIPS	20%	25V	C0603
C4	2222-916-16736	10n	X7R	PHILIPS	20%	25V	C0603
C5	2222-916-16736	10n	X7R	PHILIPS	20%	25V	C0603
C12	2222-786-16749	100n	X7R	PHILIPS	20%	16V	C0603
C19	2222-916-16736	10n	X7R	PHILIPS	20%	25V	C0603
C20	2222-916-16736	10n	X7R	PHILIPS	20%	25V	C0603
C21	2222-916-16736	10n	X7R	PHILIPS	20%	25V	C0603
C22	2222-916-16736	10n	X7R	PHILIPS	20%	25V	C0603
C23	2222-916-16736	10n	X7R	PHILIPS	20%	25V	C0603
C41	2222-916-16736	10n	X7R	PHILIPS	20%	25V	C0603
D1	HLMP6500-011	RED	Diffused_Lens	FARNELL			SMDLED
D2	HLMP6400-011	GREEN	Diffused_Lens	FARNELL			SMDLED
IC1	PN-TZA3019C	TZA3019C	IC_Universal	PHILIPS			SOT560AA1
L7	BLM11P300S	BLM11P300S	CBD	muRata			BLM11
L8	BLM11P300S	BLM11P300S	CBD	muRata			BLM11
L9	BLM11P300S	BLM11P300S	CBD	muRata			BLM11
L10	BLM11P300S	BLM11P300S	CBD	muRata			BLM11
L11	BLM11P300S	BLM11P300S	CBD	muRata			BLM11
L12	4330-030-36301	BD8.933-4S2	CBD	PHILIPS			CBD8.9
P1	142-0701-851	SMA_sqr	COAX	EF.Johnson			SMA_sqr
P2	142-0701-851	SMA_sqr	COAX	EF.Johnson			SMA_sqr
P3	142-0701-851	SMA_sqr	COAX	EF.Johnson			SMA_sqr
P4	142-0701-851	SMA_sqr	COAX	EF.Johnson			SMA_sqr
P5	142-0701-851	SMA_sqr	COAX	EF.Johnson			SMA_sqr
P6	142-0701-851	SMA_sqr	COAX	EF.Johnson			SMA_sqr
P7	142-0701-851	SMA_sqr	COAX	EF.Johnson			SMA_sqr
P8	142-0701-851	SMA_sqr	COAX	EF.Johnson			SMA_sqr
P9	R114426	SMB_str	COAX	RADIALL			SMB_str
P10	R114426	SMB_str	COAX	RADIALL			SMB_str
P11	3833-1-0-303	MKS3830_3p	MKS3830	STOCKO			3830_3p
R7	3006P-7-104BRN	100k	3006P	BOURNS	10%	0.75W	BO3006P
R8	2322-702-60333	33k	RC21	PHILIPS	5%	0.063W	R0603
R9	3006P-7-104BRN	100k	3006P	BOURNS	10%	0.75W	BO3006P
R10	2322-702-60333	33k	RC21	PHILIPS	5%	0.063W	R0603
R11	2322-702-60563	56k	RC21	PHILIPS	5%	0.063W	R0603

**OM5808 demo board negative supply for 2.5 Gb/s
TZA3014 / TZA3019 with HBCC package**
**Application Note
AN01022**

TABLE 12 Bill of materials TZA3019C, sorted by reference.

REF	Part number	Comp	Series	Vendor	Tolerance	Rating	Geom
R12	2322-702-60563	56k	RC21	PHILIPS	5%	0.063W	R0603
R15	3006P-7-104BRN	100k	3006P	BOURNS	10%	0.75W	BO3006P
R16	3006P-7-104BRN	100k	3006P	BOURNS	10%	0.75W	BO3006P
S1	2422-120-00551	DIP-SW_4	print_switch	HONYWELL			SWITCH_4
S2	09-03201-02	SPDT	print_switch	SPOERLE			Low profile
S3	09-03201-02	SPDT	print_switch	SPOERLE			Low profile
Z1	9331-177-20153	BZX79C	BZX79C	PHILIPS		5V1	SOD27
	8222-411-48321	PR48321		PS-SLE			BOARD

5.5 Layout considerations

- Decoupling networks
 - power supply decoupling
 - local decoupling, close to the IC
- 50 Ohm impedance, for input and output transmission lines
- Clearance between transmission line and ground plane for impedance matching

5.6 Thermal considerations

- Radiator inside board at first inner layer and bottom layer. The location of the components and via's were chosen to epitomize a heat flow from the radiators.

THIS PAGE IS INTENTIONALLY LEFT BLANK

**OM5808 demo board negative supply for 2.5 Gb/s
TZA3014 / TZA3019 with HBCC package**

**Application Note
AN01022**

6. Layout

6.1 Silk screen (top)

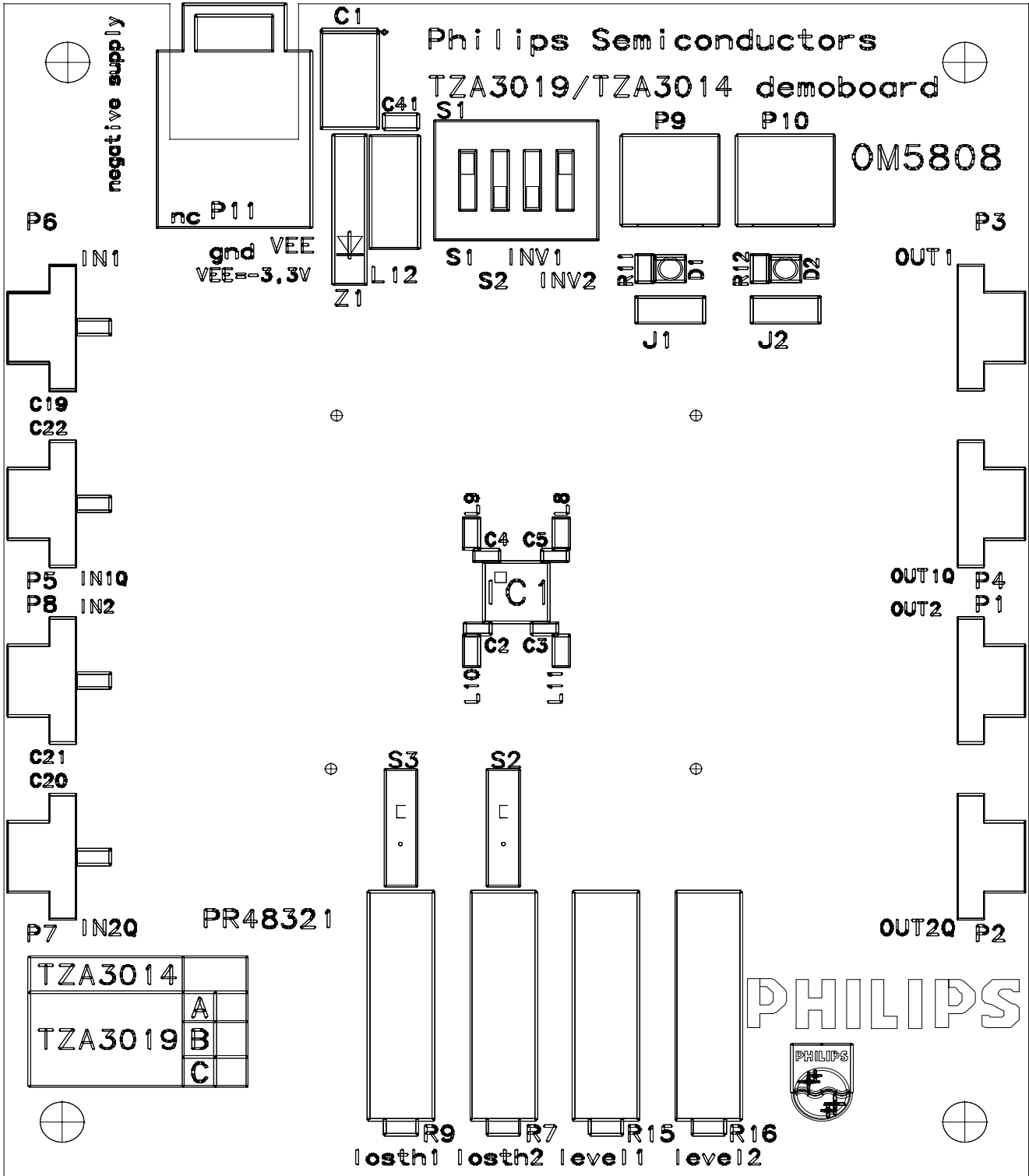

6.2 Top layer component placement

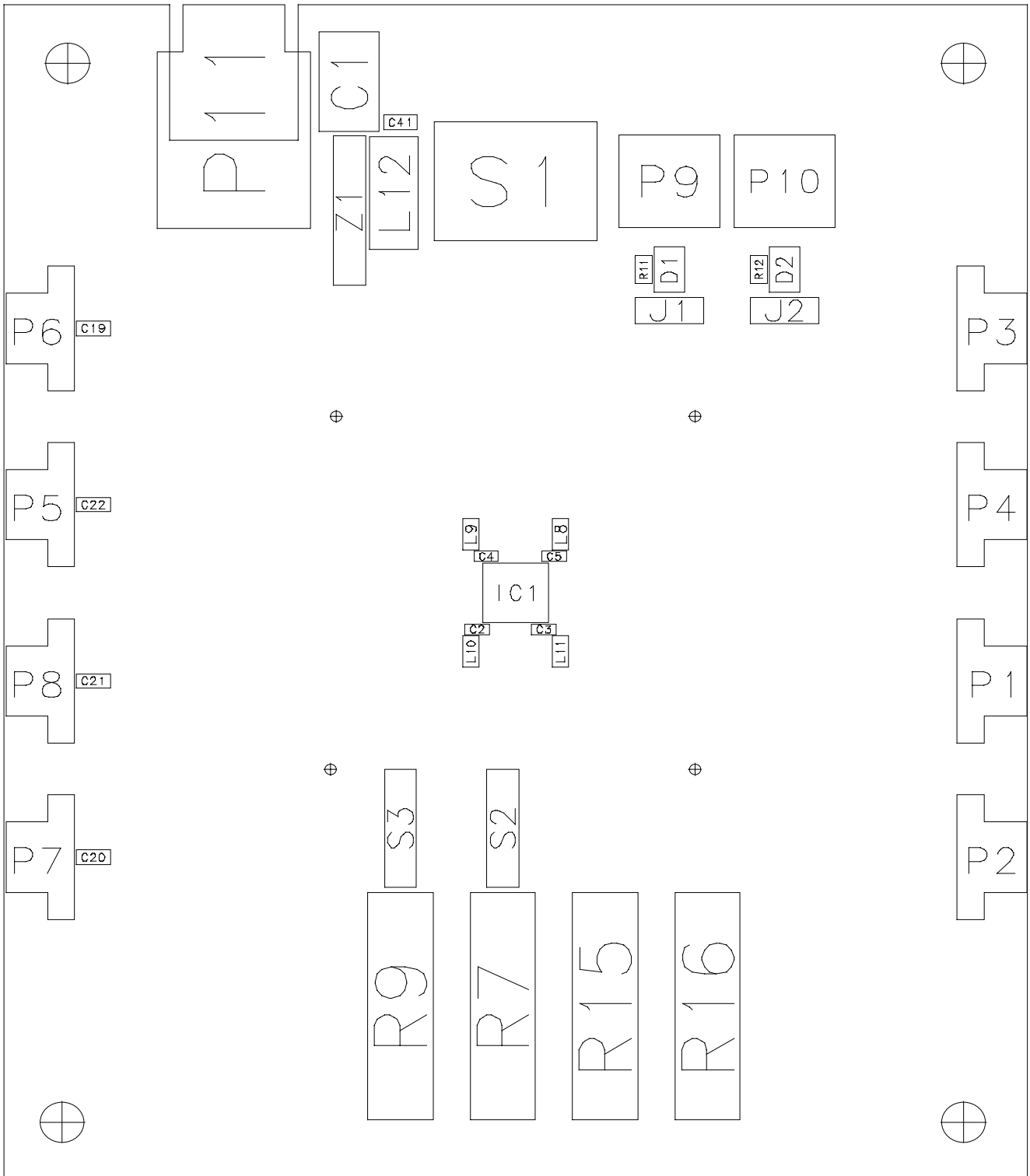

6.3 Top layer copper, inverted

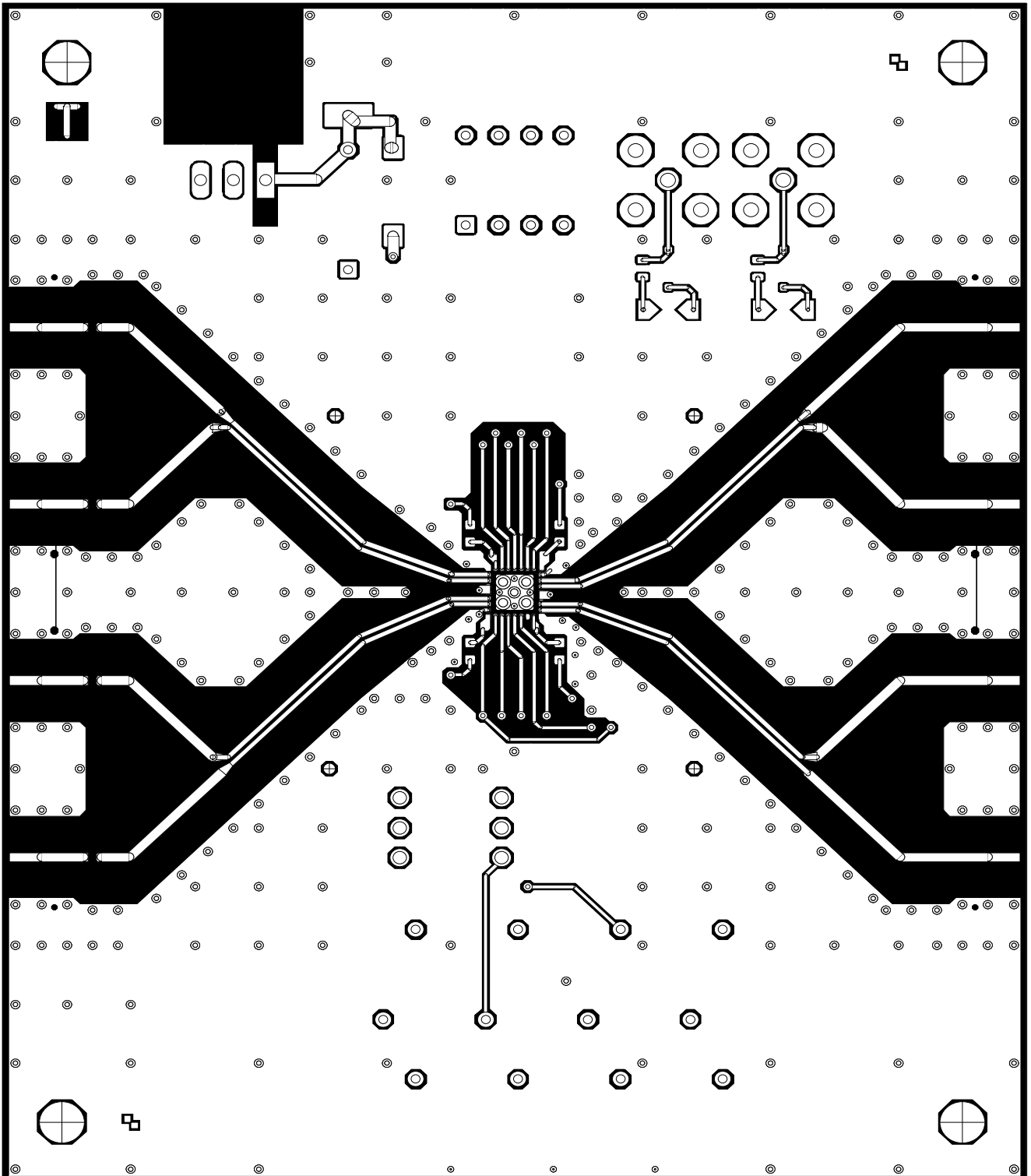

6.4 First inner layer copper, inverted

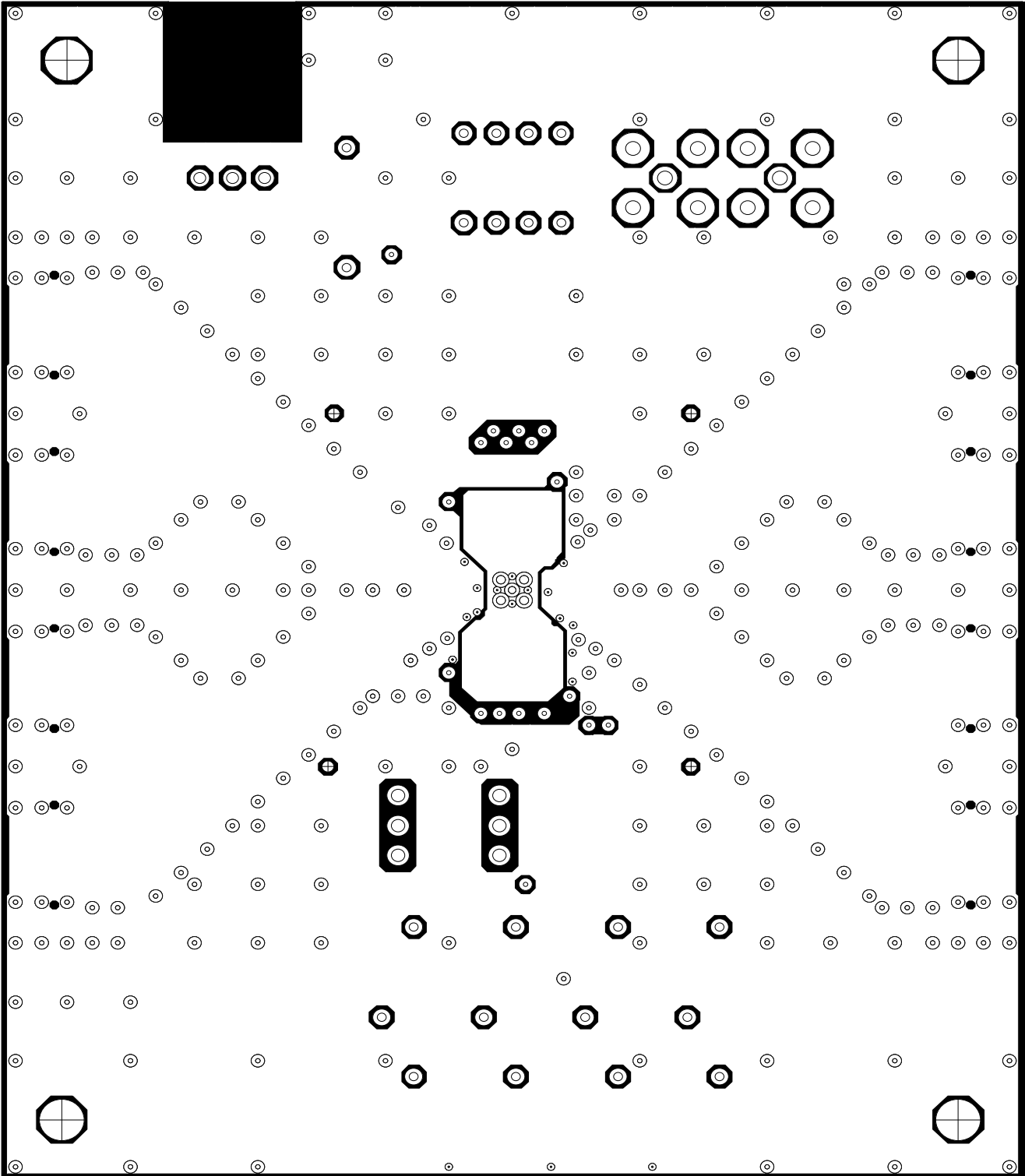

6.5 Second inner layer copper, inverted

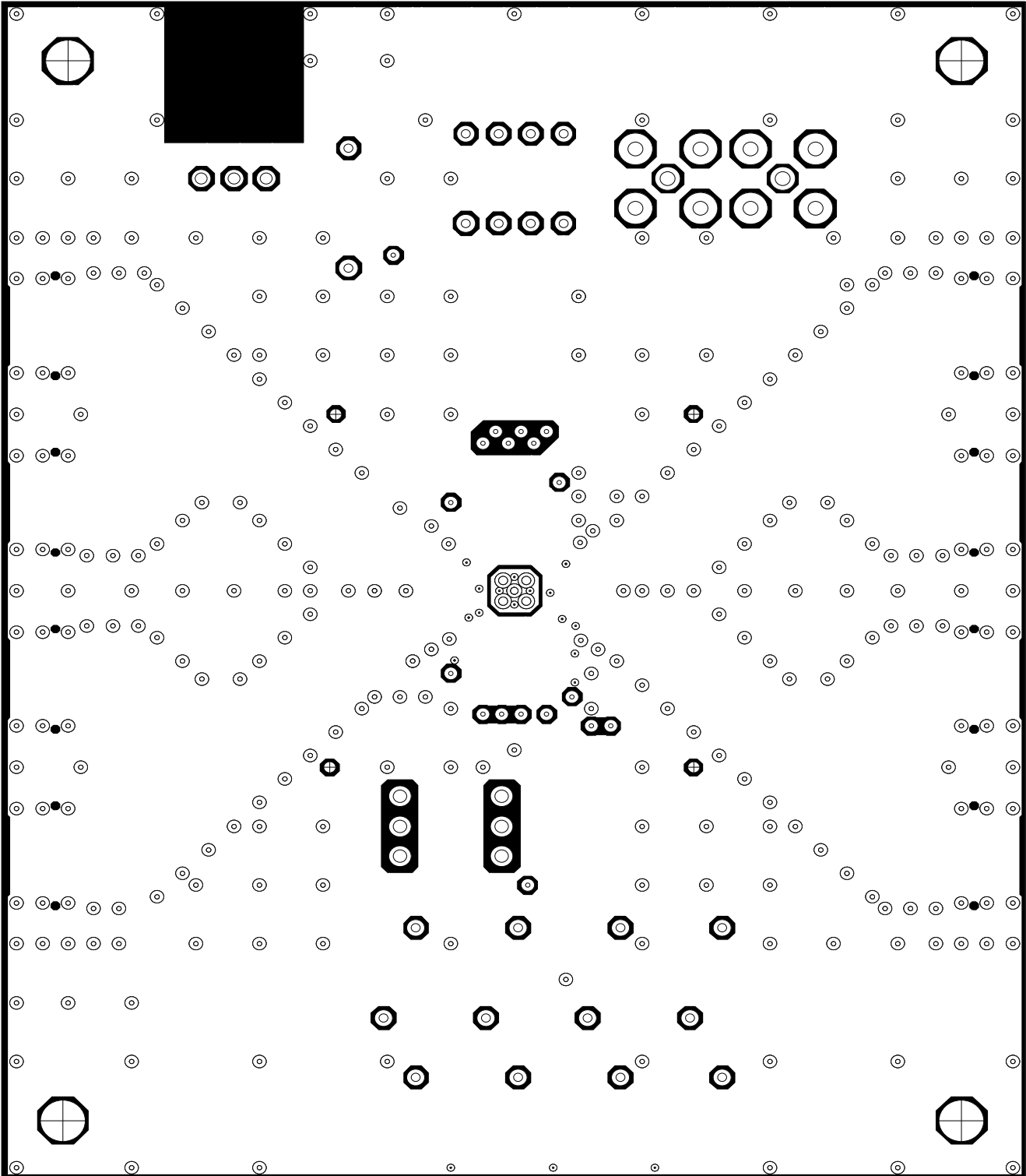

6.6 Bottom layer copper, inverted

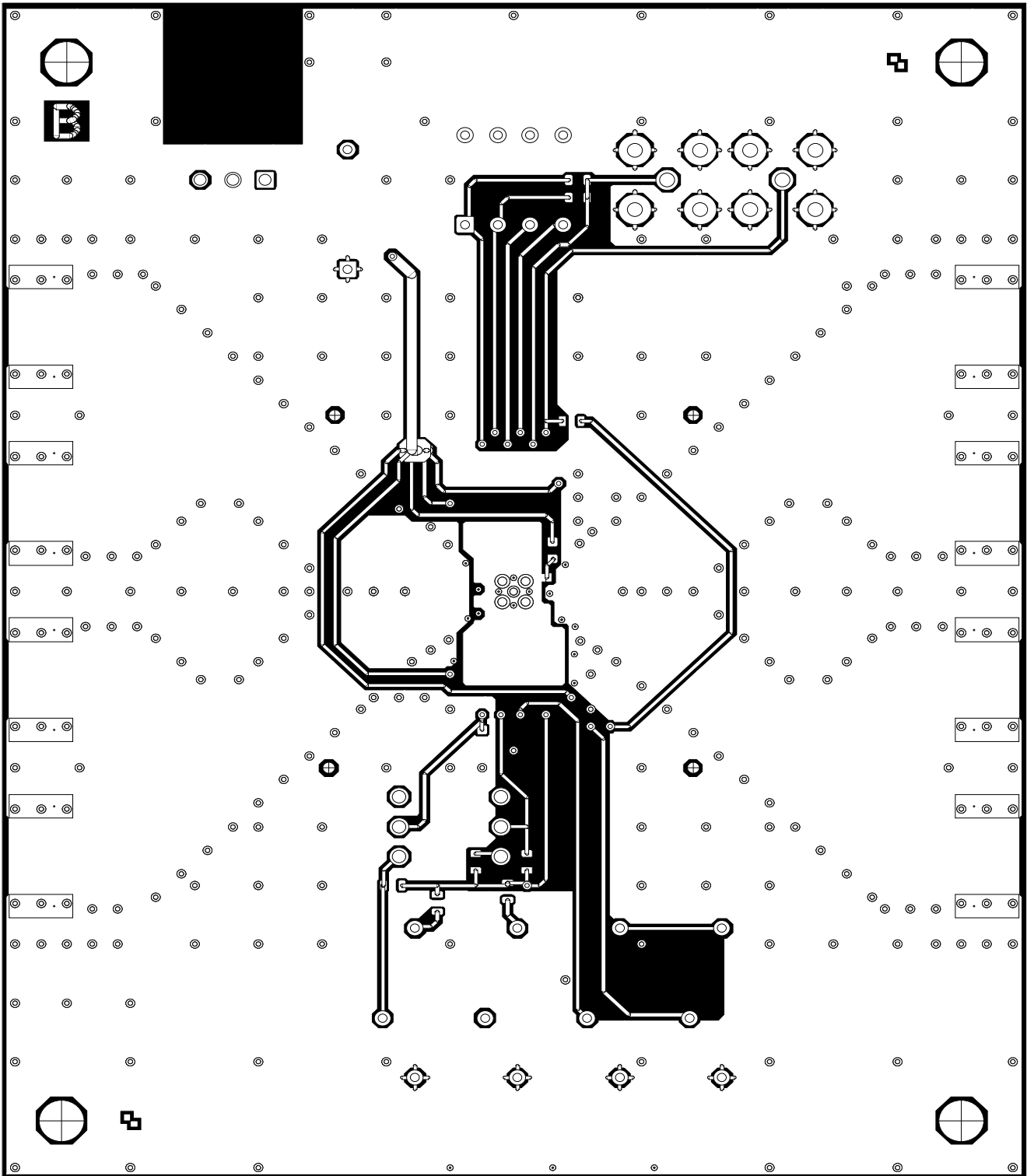

6.7 Bottom component placement (bottom view)

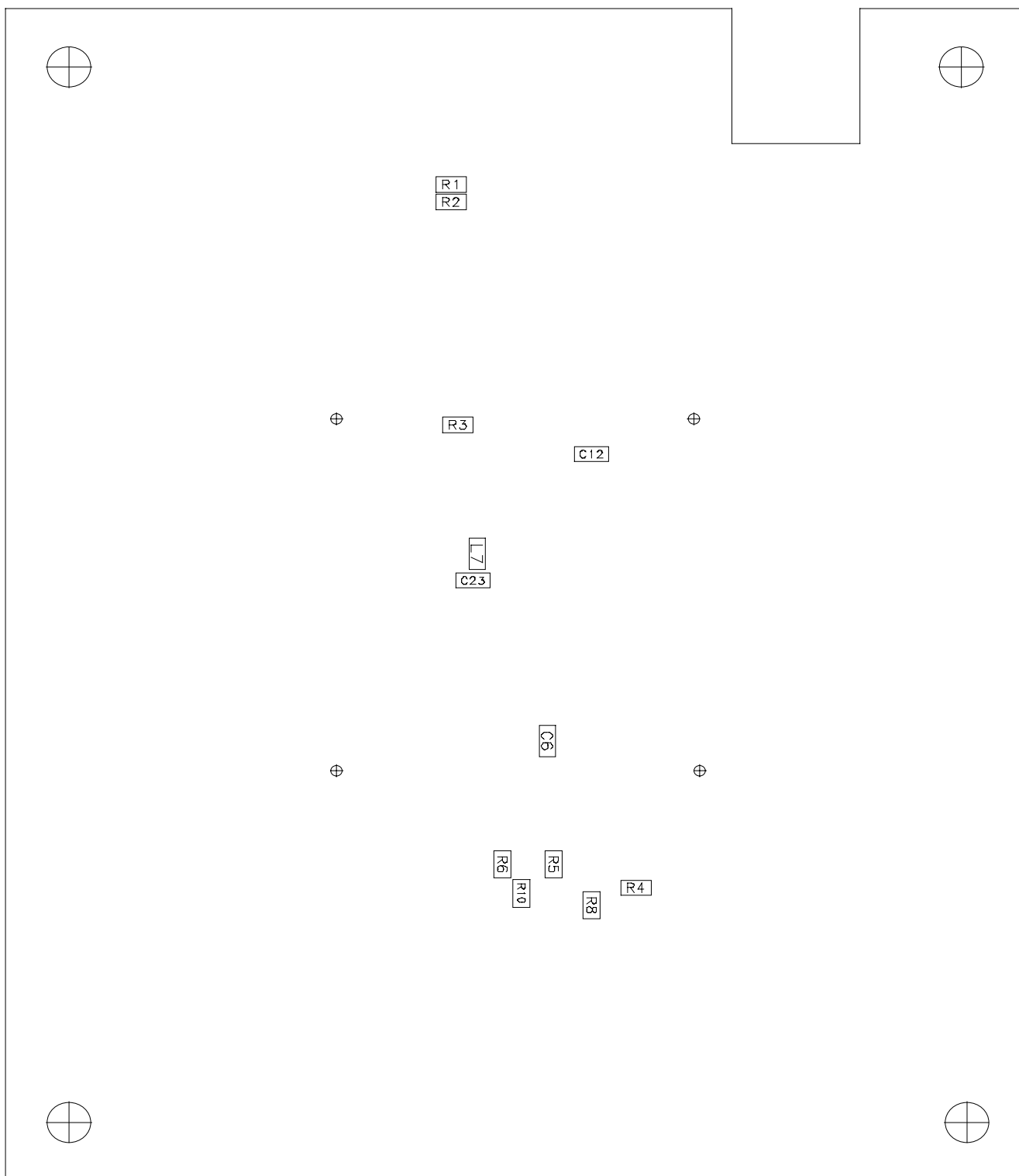

6.8 Silk screen (bottom view)

